

Conservation of Fuel and Energy - Buildings other than Dwellings

Building Regulations 2008

Technical Guidance Document



Comhshaol, Oidhreacht agus Rialtas Áitiúil
Environment, Heritage and Local Government



Building Regulations 2008

Technical Guidance Document L

Conservation of Fuel and Energy - Buildings other than Dwellings

BAILE ÁTHA CLIATH
ARNA FHOILSIÚ AG OIFIG AN TSOLÁTHAIR
LE CEANNACH DÍREACH ON
OIFIG DHÍOLTA FOILSEACHÁN RIALTAIS,
TEACH SUN ALLIANCE, SRÁID THEACH LAIGHEAN, BAILE ÁTHA CLIATH 2,
NO TRID AN BPOST O
FOILSEACHÁN RIALTAIS, AN RANNÓG POST-TRÁCHTA,
AONAD 20 PÁIRC MIONDÍOLA COIS LOCHA, CLÁR CHLAINNE MHUIRIS,
CONTAE MHAIGH EO
(TEIL: 01-6476834 / 37 NO 1890 213434; FAX: 01-6476843 NO 094-9378964)
NO TRI AON DIOLTOIR LEABHAR.

DUBLIN
PUBLISHED BY THE STATIONERY OFFICE
TO BE PURCHASED DIRECTLY FROM THE
GOVERNMENT PUBLICATIONS SALE OFFICE
SUN ALLIANCE HOUSE, MOLESWORTH STREET, DUBLIN 2,
OR BY MAIL ORDER FROM
GOVERNMENT PUBLICATIONS, POSTAL TRADE SECTION,
UNIT 20 LAKESIDE RETAIL PARK, CLAREMORRIS, CO. MAYO
(TEL: 01-6476834 / 37 OR 1890 213434; FAX: 01-6476843 OR 094 9378964)
OR THROUGH ANY BOOKSELLER.

€12

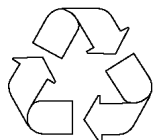

Printed on recycled paper containing a minimum of 75% post-consumer waste

Contents

	Page
Introduction	5
Transitional Arrangements	5
The Guidance	5
Existing Buildings	5
Technical Specifications	5
Materials and Workmanship	6
Interpretation	6
Building Regulations - The Requirement	7
Section 0: General Guidance	
0.1 Application of the Regulations	9
0.2 Technical Risks and Precautions	11
0.2.1 General	11
0.2.2 Fire Safety	11
0.2.3 Ventilation	11
0.3 Thermal Conductivity and Thermal Transmittance	11
0.4 Dimensions	12
0.5 Definitions	12
0.6 Application to Buildings of Architectural or Historical Interest	13
Section 1: Buildings other than Dwellings	
1.1 Limitation of Primary Energy Use and CO ₂ emissions for New Buildings other than Dwellings	15
1.2 Heat Loss and Gain through the Building Fabric	16
1.2.1 Heat Loss - General	16
1.2.2 Overall Heat Loss Method	16
1.2.3 Elemental Heat Loss Method	17
1.2.4 Thermal Bridging	18
1.2.5 Air Infiltration	21
1.2.6 Avoiding Solar Overheating	21
1.3 Building Services	23
1.3.1 Heating Plant Efficiency	23
1.3.2 Controls for Space Heating and Hot Water Supply Systems	23
1.3.3 Air Conditioning and Mechanical Ventilation (ACMV)	23
1.3.4 Insulation of Storage Vessels, Pipes and Ducts	24
1.3.5 Artificial Lighting	24

Appendices

A	Calculation of U-values	27
B	Fabric Insulation: Additional Guidance (including Tables of U-Values) for Common Constructions	35
C	Reference Values for Calculation of Maximum Permitted Energy Performance Coefficient (MPEPC) and Maximum Permitted Carbon Performance Coefficient (MPCPC)	57
D	Thermal Bridging	60
E	Avoidance of Solar Overheating	62

STANDARDS AND OTHER REFERENCES **65**

Building Regulations 2008

Technical Guidance Document L

Conservation of Fuel and Energy - Buildings other than Dwellings

Introduction

This document has been published by the Minister for the Environment, Heritage and Local Government under article 7 of the Building Regulations 1997.

It provides guidance in relation to Part L of the Second Schedule to the Regulations as inserted by Building Regulations (Part L Amendment) Regulations 2008 (S.I. No. 259 of 2008). The guidance in this document applies to buildings other than dwellings.

These Regulations (and this document) partly transpose the **EU Energy Performance of Buildings Directive - EPBD (2002/91/EC of 16 December 2002)**.

The document should be read in conjunction with the Building Regulations 1997-2005 and other documents published under these Regulations.

In general, Building Regulations apply to the construction of new buildings and to extensions and material alterations to existing buildings. In addition, certain parts of the Regulations apply to existing buildings where a material change of use takes place. (Otherwise, Building Regulations do not apply to buildings constructed prior to 1 June 1992).

Transitional Arrangements

In general, this document applies to works, or buildings in which a material alteration or change of use takes place, where the work, material alteration or the change of use commences or takes place, as the case may be, on or after 10 July 2008.

Technical Guidance Document L - Conservation of Fuel and Energy (May 2006 edition) ceases to have effect from 9 July 2008.

However, this document may continue to be used in the case of buildings:

- where the work, material alteration or the change of use commences or takes place, as the case may be, on or before 30 June 2008, or
- where planning approval or permission has been applied for on or before 30 June 2008, and substantial work has been completed by 30 June 2010.

“Substantial work has been completed” means that the structure of the external walls has been erected.

The Guidance

The materials, methods of construction, standards and other specifications (including technical specifications)

which are referred to in this document are those which are likely to be suitable for the purposes of the Building Regulations (as amended). Where works are carried out in accordance with the guidance in this document, this will, prima facie, indicate compliance with Part L of the Second Schedule to the Building Regulations.

However, the adoption of an approach other than that outlined in the guidance is not precluded provided that the relevant requirements of the Regulations are complied with. Those involved in the design and construction of a building may be required by the relevant building control authority to provide such evidence as is necessary to establish that the requirements of the Regulations are being complied with.

Existing Buildings

In the case of material alterations or change of use of existing buildings, the adoption without modification of the guidance in this document may not, in all circumstances, be appropriate. In particular, the adherence to guidance, including codes, standards or technical specifications intended for application to new work may be unduly restrictive or impracticable.

Buildings of architectural or historical interest are especially likely to give rise to such circumstances. In these situations, alternative approaches based on the principles contained in the document may be more relevant and should be considered.

Technical Specifications

Building Regulations are made for specific purposes, e.g. to provide, in relation to buildings, for the health, safety and welfare of persons, the conservation of energy, and access for people with disabilities.

Technical specifications (including harmonised European Standards, European Technical Approvals, National Standards and Agreement Certificates) are relevant to the extent that they relate to these considerations.

Any reference to a technical specification is a reference to so much of the specification as is relevant in the context in which it arises. Technical specification may also address other aspects not covered by the Regulations.

A reference to a technical specification is to the latest edition (including any amendments, supplements or addenda) current at the date of publication of this Technical Guidance Document. However, if this version of the technical specification is subsequently revised or updated by the issuing body, the new version may be used as a source of guidance provided that it continues to address the relevant requirements of the Regulations.

Materials and Workmanship

Under Part D of the Second Schedule to the Building Regulations, building work to which the Regulations apply must be carried out with proper materials and in a workmanlike manner. Guidance in relation to compliance with Part D is contained in Technical Guidance Document D.

Interpretation

In this document, a reference to a section, paragraph, appendix or diagram is, unless otherwise stated, a reference to a section, paragraph, appendix or diagram, as the case may be, of this document. A reference to another Technical Guidance Document is a reference to the latest edition of a document published by the Department of the Environment, Heritage and Local Government under article 7 of the Building Regulations 1997.

Diagrams are used in this document to illustrate particular aspects of construction - they may not show all the details of construction.

Conservation of Fuel and Energy

Building Regulations - The Requirement

The requirements regarding conservation of fuel and energy are laid out in Part L of the Second Schedule to the Building Regulations 1997 (S.I. No. 497 of 1997) as amended by the Building Regulations (Part L Amendment) Regulations 2008 (S.I. No. 259 of 2008).

The Second Schedule is amended to read, in relation to buildings other than dwellings, as follows:

Conservation of Fuel and Energy	L1	A building shall be designed and constructed so as to ensure that the energy performance of the building is such as to limit the amount of energy required for the operation of the building and the amount of CO ₂ emissions associated with this energy use insofar as is reasonably practicable.
Buildings other than dwellings	L4	<p>For buildings other than dwellings, the requirements of L1 shall be met by:</p> <ul style="list-style-type: none">(a) providing that the energy performance of the new building is such as to limit the calculated primary energy consumption and related CO₂ emissions insofar as is reasonably practicable, when both energy consumption and CO₂ emissions are calculated using the Non-domestic Energy Assessment Procedure (NEAP) published by Sustainable Energy Ireland;(b) limiting the heat loss and, where appropriate, maximising the heat gains through the fabric of the building;(c) providing energy efficient space and water heating services including adequate control of these services;(d) ensuring that the building is appropriately designed to limit need for cooling and, where air-conditioning or mechanical ventilation is installed, that installed systems are energy efficient, appropriately sized and adequately controlled;(e) limiting the heat loss from pipes, ducts and vessels used for the transport or storage of heated water or air;(f) limiting the heat gains by chilled water and refrigerant vessels, and by pipes and ducts that serve air conditioning systems;(g) providing energy efficient artificial lighting systems (other than emergency lighting, display lighting or specialist process lighting) and adequate control of these systems.

Section 0:
General Guidance

0.1 APPLICATION OF THE REGULATIONS

0.1.1 The aim of Part L of the First Schedule to the Building Regulations is to limit the use of fossil fuel energy and related CO₂ emissions arising from the operation of buildings, while ensuring that occupants can achieve adequate levels of lighting and thermal comfort. Buildings should be designed and constructed to achieve this aim as far as is practicable.

0.1.2 For new buildings other than dwellings, the key issues to be addressed in order to ensure compliance are:

- a. to provide that the calculated primary energy consumption associated with the operation of the building and the related CO₂ emissions as described in Section 1.1 do not exceed a target value specified in this document;
- b. to limit the heat loss and, where appropriate, maximise the heat gains through the fabric of the building;
- c. to provide energy efficient space and water heating services including adequate control of these services;
- d. to ensure that the building is appropriately designed to limit the need for cooling and, where air-conditioning or mechanical ventilation is installed, that installed systems are energy efficient, appropriately sized and adequately controlled;
- e. to limit the heat loss from pipes, ducts and vessels used for the transport or storage of heated water or air;
- f. to limit the heat gains by chilled water and refrigerant vessels, and by pipes and ducts that serve air conditioning systems;
- g. to provide energy efficient artificial lighting systems (other than emergency lighting, display lighting or specialist process lighting) and adequate control of these systems.

The principal aims of Part L of the Building Regulations are to limit primary energy consumption and associated CO₂ emissions. Meeting the performance levels specified for items b to g will not necessarily mean that the level specified for primary energy consumption and related CO₂ emissions (item a) will be met. It is likely that one or more of the performance levels specified, for items b to g, will need to be exceeded to achieve this.

0.1.3 Where a dwelling has an attached room or space that is to be used for commercial purposes (e.g. workshop, surgery, consulting room or office), such room or space should be treated as part of the dwelling if the commercial part could revert to domestic use on a change of ownership, e.g. where there is direct access between the commercial space and the living accommodation, both are contained within the same thermal envelope and the living accommodation occupies a substantial proportion of the total area of the building.

0.1.4 The guidance given in this Technical Guidance Document is generally applicable. However, where the works are limited in nature and not likely to greatly affect overall energy consumption over the building's life, compliance may be achieved without implementation of this guidance or equivalent measures in detail. In particular,

- For small extensions, not exceeding 6.5m² in floor area, reasonable provision can be considered to have been made if the new construction is similar to the existing construction.
- Unheated ancillary areas such as porches, garages and the like do not require specific provisions in order to satisfy this Part of the Building Regulations.
- Where the area treated by an Air Conditioning and Mechanical Ventilation (ACMV) system is less than 200 m², the guidance in relation to ACMV systems need not be applied.
- Where the total design lighting load does not exceed 1000 W, the guidance in relation to the efficiency and control of artificial lighting need not be applied.

0.1.5 The guidance given in this Technical Guidance Document applies to buildings designed to be heated to temperatures appropriate for human occupancy. Less demanding standards could represent reasonable provision in those buildings or parts of buildings with a low level of heating or where heating provision is not intended. Low level of heating is considered to be where there is an installed heating capacity of less than 10W/m².

Where the occupancy level or level of heating required when in use cannot be established at construction stage, the building should be treated as fully heated and the provisions of Part L applied accordingly. It should be noted that the provisions of Part L apply where a material change of use occurs and such a change of use may require specific construction measures to comply with Part L. These measures may prove more costly than if carried out at the time of initial construction.

0.1.6 An attached conservatory-style sunspace or the like should generally be treated as an integral part of the building to which it is attached. However, where

- thermally separated from the adjacent spaces within the building by walls, doors and other opaque elements which have U-values not more than 10% greater than corresponding exposed elements, and
- unheated or, if providing with a heating facility, having provision for automatic temperature and on-off control independent of the heating provision in the main building,

it may be excluded from the assessment of the building for the purposes of assessing compliance with the provisions of Part L. In this case, the building may be assessed separately for compliance. The attached sunspace should be treated as an unheated space for the purposes of this assessment and should also be assessed separately as if it were an extension to an existing building (see Paragraph 1.2.3.3 below).

0.1.7 In large complex buildings it may be sensible to consider the provisions for conservation of fuel and energy separately for different parts of the

building in order to establish the measures appropriate to each part.

0.1.8 The Regulations apply to all works to existing buildings that are covered by the requirements of the Building Regulations, including extensions, material alterations, material changes of use and window and door replacement. In carrying out this work, the aim should be to limit energy requirements for the operation of the building and associated CO₂ emissions as far as practicable as required by Regulation LI.

The key issues to be addressed are:

- (a) limiting the heat loss and, where appropriate, maximising the heat gains through the fabric of the building;
- (b) providing energy efficient space and water heating services including adequate control of these services;
- (c) ensuring that the building is appropriately designed to limit need for cooling and, where air-conditioning or mechanical ventilation is installed, that installed systems are energy efficient, appropriately sized and adequately controlled;
- (d) limiting the heat loss from pipes, ducts and vessels used for the transport or storage of heated water or air;
- (e) limiting the heat gains by chilled water and refrigerant vessels, and by pipes and ducts that serve air conditioning systems;
- (f) providing energy efficient artificial lighting systems (other than emergency lighting, display lighting or specialist process lighting) and adequate control of these systems.

0.2 TECHNICAL RISKS AND PRECAUTIONS

General

0.2.1 The incorporation of additional thickness of thermal insulation and other energy conservation measures can result in changes in traditional construction practice. Care should be taken in design and construction to ensure that these changes do not increase the risk of certain types of problems, such as rain penetration and condensation.

Some guidance on avoiding such increased risk is given in [Appendix B](#) of this document. General guidance on avoiding risks that may arise is also contained in the publication “*Thermal insulation: avoiding risks; Building Research Establishment (Ref BR 262)*”.

Guidance in relation to particular issues and methods of construction will be found in relevant standards.

Fire Safety

0.2.2 Part B of the Second Schedule to the Building Regulations prescribes fire safety requirements. In designing and constructing buildings to comply with Part L, these requirements must be met and the guidance in relation to fire safety in TGD B should be fully taken into account. In particular, it is important to ensure that windows, which provide secondary means of escape in accordance with Section 1.5 of TGD B, comply with the dimensional and other guidance for such windows set out in paragraph 1.5.6 of TGD B.

Ventilation

0.2.3 Part F of the Second Schedule to the Building Regulations prescribes ventilation requirements both to meet the needs of the occupants of the building and to prevent excessive condensation in roofs and roofspaces. A key aim of the provisions in relation to the ventilation of occupied spaces is to minimize the risk of condensation, mould growth or other indoor air quality problems. Technical Guidance Document F provides guidance in relation to ventilation of buildings.

Part J of the Second Schedule to the Building Regulations prescribes requirements in relation to the supply of air for combustion appliances, including open-flued appliances which draw air from the room or space in which they are situated. Technical Guidance Document J provides guidance in this regard.

0.3 THERMAL CONDUCTIVITY AND THERMAL TRANSMITTANCE

0.3.1 Thermal conductivity (λ -value) relates to a material or substance, and is a measure of the rate at which heat passes through a uniform slab of unit thickness of that material or substance, when unit temperature difference is maintained between its faces. It is expressed in units of Watts per metre per degree (W/mK).

0.3.2 For the purpose of showing compliance with this Part of the Building Regulations, design λ -values based on manufacturers declared values should be used. For thermally homogeneous materials declared and design values should be determined in accordance with I.S. EN ISO 10456: 1997. Design values for masonry materials should be determined in accordance with I.S. EN 1745: 2002. For insulation materials, values determined in accordance with the appropriate harmonized European standard should be used. Certified λ -values for foamed insulant materials should take account of the blowing agent actually used. The use of HCFC for this purpose is no longer permitted.

For products or components for which no appropriate standard exists, measured values, certified by an approved body or certified laboratory (see TGD D), should be used.

0.3.3 [Table A1](#) and [A2](#) of [Appendix A](#) contains λ -values for some common building materials and insulation materials. These are primarily based on data contained in I.S. EN 12524: 2000 or in CIBSE Guide A, Section A3. The values provide a general indication of the thermal conductivity that may be expected for these materials. In the absence of declared values, design values or certified measured values as outlined in paragraph 0.3.2, values of thermal conductivity given in [Table A1](#) may be used. However, values for specific products may differ from these illustrative values. Indicative λ -values for

thermal insulation materials are given [Table A2](#). These may be used at early design stage for the purpose of assessing likely compliance with this Part of the Regulations. However, compliance should be verified using thermal conductivity values for these materials derived as outlined in Paragraph 0.3.2 above.

0.3.4 Thermal transmittance (U-value) relates to a building component or structure, and is a measure of the rate at which heat passes through that component or structure when unit temperature difference is maintained between the ambient air temperatures on each side. It is expressed in units of Watts per square metre per degree of air temperature difference (W/m²K).

0.3.5 Thermal transmittance values (U-values) relevant to this Part of the Regulations are those relating to elements exposed directly or indirectly to the outside air. This includes floors directly in contact with the ground, suspended ground floors incorporating ventilated or unventilated voids, and elements exposed indirectly via unheated spaces. The U-value takes account of the effect of the ground, voids and unheated spaces on the rate of heat loss, where appropriate. Heat loss through elements that separate premises that can reasonably be assumed to be heated, is considered to be negligible. Such elements do not need to meet any particular U-value nor should they be taken into account in calculation of CO₂ emissions or overall transmission heat loss.

0.3.6 A range of methods exists for calculating U-values of building elements. Methods of calculation are outlined in [Appendix A](#), together with examples of their use. Alternatively U-values may be based on certified measured values. Measurements of thermal transmission properties of building components generally should be made in accordance with I.S. EN ISO 8990: 1997, or, in the case of windows and doors, I.S. EN ISO 12567-1: 2001.

0.3.7 Any part of a roof that has a pitch of 70° or more may be treated as a wall for the purpose of assessing the appropriate level of thermal transmission. Elements separating the building from spaces that can reasonably be assumed to be heated should not be included .

0.3.8 [Appendix B](#) contains tables of indicative U-values for certain common constructions. These are derived using the calculation methods referred to in [Appendix A](#), and may be used in place of calculated or measured values, where appropriate. These tables provide a simple way to establish the U-value for a given amount of insulation. Alternatively they may be used to establish the amount of insulation needed to achieve a given U-value. The values in the tables have been derived taking account of typical repeated thermal bridging where appropriate. Where an element incorporates a non-repeating thermal bridge, e.g. where the continuity of insulation is broken or penetrated by material of reduced insulating quality, the U-value derived from the table should be adjusted to account for this thermal bridge. [Table B24](#) in [Appendix B](#) contains indicative U-values for external doors, windows and rooflights (roof windows).

0.4 DIMENSIONS

0.4.1 Except where otherwise indicated linear measurements for the calculation of wall, roof and floor areas and building volumes should be taken between the finished internal faces of the appropriate external building elements and, in the case of roofs, in the plane of the insulation. Linear measurements for the calculation of the areas of external door, window and rooflight openings should be taken between internal faces of appropriate cills, lintels and reveals.

0.4.2 "Volume" means the total volume enclosed by all enclosing elements and includes the volume of non-usable spaces such as ducts, stairwells and floor voids in intermediate floors.

0.5 DEFINITIONS

0.5.1 For the purposes of this Technical Guidance Document the following definitions apply:

Energy Use (for a particular purpose e.g. space heating, water heating, repeat cooling, ventilation, lighting): Energy input to the relevant system to satisfy the relevant purpose.

Delivered Energy: Energy supplied to the building and its systems to satisfy the relevant energy uses e.g.

space heating, water heating, cooling, ventilation, lighting. Delivered energy does not include renewable energy produced on site.

Delivered energy differs from energy use by the extent of on-site conversion and transformation losses e.g. boiler efficiency losses.

Primary Energy: Energy that has not been subjected to any conversion or transformation process. For a building, it is the delivered energy plus the energy used to produce the energy delivered to the building. It is calculated from the delivered energy, with an allowance for any energy exported from the site, using conversion factors.

Renewable Energy: Energy from renewable non-fossil energy sources e.g. solar energy (thermal and photovoltaic), wind, hydropower, biomass, geothermal, wave, tidal, landfill gas, sewage treatment plant gas and biogases.

Biomass: Biodegradable fraction of products, waste and residues from agriculture (including vegetal and animal substances), forestry and related industries, as well as biodegradable fraction of industrial and municipal waste, used as a fuel or energy source. Fuels derived from biomass may be in solid, liquid or gas form. In this document, where the term “biomass” is used on its own, it should be taken to mean solid biomass (wood, wood chip, wood pellet, etc).

Biofuel: Liquid or gas fuel derived from biomass.

Note: *Biomass* (including biofuel) is generally included in Delivered Energy and thus, together with the energy used to produce and deliver it, included in *Primary Energy*.

0.6 APPLICATION TO BUILDINGS OF ARCHITECTURAL OR HISTORICAL INTEREST

0.6.1 Part L does not apply to works (including extensions) to an existing building which is a “protected structure” or a ‘proposed protected structure’ within the meaning of the Planning and Development Act 2000 (No 30 of 2000).

Nevertheless, the application of this Part may pose particular difficulties for buildings which, although not protected structures or proposed protected structures may be of architectural or historical interest.

Works such as the replacement of doors, windows and rooflights, the provision of insulated dry lining and damp-proofing to walls and basements, insulation to the underside of slating and provision of roof vents and ducting of pipework could all affect the character of the structure.

In general, the type of works described above should be carefully assessed for their material and visual impact on the structure.

Historic windows and doors should be repaired rather than replaced, and drylining and damp-proofing should not disrupt or damage historic plasterwork or flagstones and should not introduce further moisture into the structure.

Roof insulation should be achieved without damage to slating (either during the works or from erosion due to condensation) and obtrusive vents should not affect the character of the roof.

In specific cases, relaxation of the values proposed may be acceptable, to the local building control authority, if it can be shown to be necessary in order to preserve the architectural integrity of the particular building.

For more guidance on appropriate measures see “*Planning Guidelines No. 9: Architectural Heritage Protection - Guidelines for Planning Authorities*” published by the Department of the Environment, Heritage and Local Government.

*Section 1: Buildings other than
Dwellings*

1.1: Limitation of Primary Energy Use and CO₂ emissions for New Buildings other than Dwellings

1.1.1 This Section provides guidance on how to show compliance with the requirements in relation to primary energy consumption and CO₂ emissions specified in Regulation L4(a). The framework for calculation to be used is specified in the Regulation as the Non domestic Energy Assessment Procedure (NEAP). This framework enables the use of either a simplified building energy method or an approved alternative method. This framework is published by Sustainable Energy Ireland (SEI) and calculates the energy consumption and CO₂ emissions associated with a standardised use of a building. The energy consumption is expressed in terms of kilowatt hours per square metre floor area per year (kWh/m²/yr) and the CO₂ emissions expressed in terms of kilograms of CO₂ per square metre floor area per year (kg CO₂/m²/yr). Full details of the framework are available on the SEI website at <http://www.sei.ie>.

1.1.2 The performance criteria are based on the relative values of the calculated primary energy consumption and CO₂ emissions of a building being assessed, and similar calculated values for a Reference Building. Details of the Reference Building are given in Appendix C. The criteria are determined as follows:

- Primary energy consumption and CO₂ emissions for both the proposed building and the reference building are calculated using NEAP.
- The calculated primary energy consumption of the proposed building is divided by that of the reference building, the result being the energy performance coefficient (EPC) of the proposed building. To demonstrate that an acceptable Primary Energy consumption rate has been achieved, the calculated EPC of the building being assessed should be no greater than the Maximum Permitted Energy Performance Coefficient (MPEPC). The MPEPC is 1.0.
- The calculated CO₂ emission rate of the proposed building is divided by that of the reference building, the result being the carbon performance coefficient (CPC) of the proposed building. To demonstrate that an acceptable CO₂ emission rate has been achieved, the calculated CPC of the building being assessed should be no greater than the

Maximum Permitted Carbon Performance Coefficient (MPCPC). The MPCPC is 1.0.

Each method within the NEAP framework will calculate the EPC and CPC of the building being assessed and clearly indicate whether compliance with the requirements of Regulation L4(a) has been achieved.

1.1.3 The requirements that the calculated EPC and CPC do not exceed the MPEPC and MPCPC respectively, applies to the constructed building. Designers may wish to calculate the EPC and CPC at early design stage in order to ensure that the requirements can be achieved by the constructed building. However, the use of constructions and service systems which have been assessed at design stage, or other model designs, does not preclude the need to verify compliance by calculating the EPC and CPC when all relevant details of the final construction are known.

1.1.4 Primary energy does not include energy derived from on-site renewable energy technologies. In addition, as renewable energy technologies generally are characterised by zero, or greatly reduced, CO₂ emissions, the calculated EPC and CPC are reduced by the extent that they replace traditional fossil fuels.

1.2: Heat Loss and Gain through the Building Fabric

1.2.1 HEAT LOSS - GENERAL

1.2.1.1 The following two methods may be used to demonstrate that an acceptable level of transmission heat loss through the elements bounding the heated building volume is achieved-

- (a) The Overall Heat Loss method (paragraph 1.2.2). This method is applicable to new buildings and extensions to existing buildings; or
- (b) The Elemental Heat Loss method (paragraph 1.2.3). While this method may be used for any building, it is primarily appropriate for small buildings, e.g. less than 300 m² floor area, small sections of large complex buildings, common areas of apartment blocks, material alterations and material changes of use.

For both methods, the guidance regarding the limitation of thermal bridging and uncontrolled air infiltration through the building fabric (paragraphs 1.2.4 and 1.2.5) and the control of overheating (paragraph 1.2.6) should be followed.

1.2.1.2 The derivation of U-values, including those applicable where heat loss is to an unheated space, is dealt with in Paragraphs 0.3.5 to 0.3.6 and [Appendix A](#).

Unheated areas which are wholly or largely within the building structure and are not subject to excessive air-infiltration or ventilation, e.g. stairwells, corridors in buildings containing flats, may be considered as within the insulated fabric. In that case, if the external fabric of these areas is insulated to the same level as that achieved by equivalent adjacent elements, no particular requirement for insulation between the heated and unheated areas would arise.

1.2.1.3 The treatment of an attached conservatory-style sunspace is dealt with in Paragraph 0.1.6. Where an attached sunspace is treated as an extension to the main building for the purposes of assessment for compliance with the provisions of Part L (as provided for in Paragraph 0.1.6), the guidance in Paragraph 1.2.3.3 should be followed.

1.2.1.4 This Part of the Building Regulations applies to the replacement of external doors, windows, or rooflights in an existing building. The average U-value of replacement units should not exceed the value of 2.2 W/m²K. The limitations on opening areas set out in [Table 3](#) do not apply. In this context, the repair or renewal of parts of individual elements, e.g. window glass, window casement sash, door leaf should be considered as repair and not replacement.

1.2.2 OVERALL HEAT LOSS METHOD

1.2.2.1 This method sets a maximum acceptable level of transmission heat loss through the fabric of a building, in terms of the maximum average U-value (U_m) of all fabric elements contributing to heat loss. The level depends on the ratio of the total area of these elements (A_t) to the building volume (V), and is specified in [Table 1](#). The acceptable level of heat loss is expressed graphically in [Diagram 1](#).

1.2.2.2 In addition to not exceeding the maximum average value set, average elemental U-values should not exceed the following:

- roofs 0.25 W/m²K
- walls 0.37 W/m²K
- exposed floors 0.37 W/m²K
- ground floors 0.37 W/m²K

Table 1 Maximum average U-value (U_m) as a function of building volume (V) and fabric heat-loss area (A_t)	
Area of Heat Loss Elements/ Building Volume (A_t/V) (m ⁻¹)	Maximum Average U-Value (U_m) (W/m ² K)
1.3	0.39
1.2	0.40
1.1	0.41
1.0	0.43
0.9	0.45
0.8	0.48
0.7	0.51
0.6	0.56
0.5	0.62
0.4	0.72
0.3	0.87

NOTE 1: The expression $U_m = 0.24 + 0.19 V/A_t$ can be used to establish U_m for intermediate values of A_t/V and for values below 0.3 m⁻¹.

Maximum average U-value (U_m) in relation to building volume (V) and total area of heat loss elements (A_t)

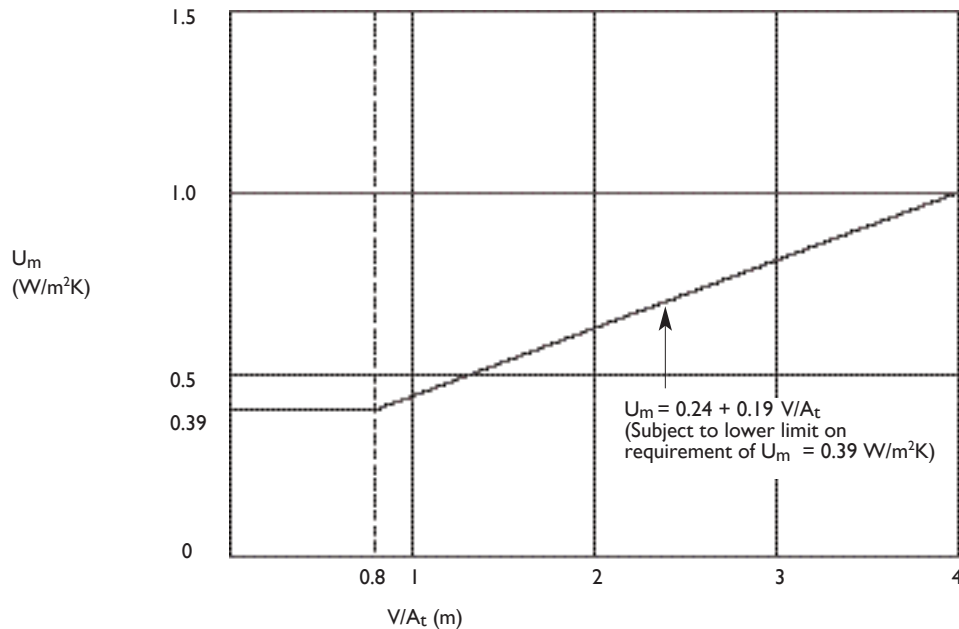

1.2.3 ELEMENTAL HEAT LOSS METHOD

1.2.3.1 To demonstrate acceptable transmission heat loss by this method, maximum average U-values for individual building elements should not exceed those set out in [Table 2](#).

1.2.3.2 The combined area of window, door and rooflight openings should not exceed the values given in [Table 3](#) when the average U-value is $2.2 \text{ W/m}^2\text{K}$. However, this area may be varied provided the total heat loss through these elements is not increased.

The area of openings provided should take account of the level of daylight provision appropriate to the building. *BS 8206: Part 2* and *CIBSE Lighting Guide (LG10)*, *Daylight and window design*, give advice on adequate daylight provision. Care should be taken in the selection and installation of glazed systems to avoid the risk of condensation. Guidance can be obtained from BRE Report No 262, *Thermal insulation: avoiding risks*.

Table 2 ELEMENTAL HEAT LOSS METHOD: Maximum average elemental U-value ($\text{W/m}^2\text{K}$)

Fabric Elements	New Buildings & Extensions to Existing Buildings	Material Alterations to, or Material Changes of Use of, Existing Buildings
Pitched roof, insulation horizontal at ceiling level	0.16	0.35
Pitched roof, insulation on slope	0.20	0.35
Flat roof	0.22	0.35
Walls	0.27	0.60
Ground Floors	0.25	-
Other Exposed Floors	0.25	0.60
External personnel doors, windows and rooflights	2.20^1	2.20
Vehicle access and similar large doors	1.5	-

NOTE 1: Permitted average U-value of external personnel doors, windows and rooflights in buildings other than dwellings may vary as described in Paragraph 1.2.3.2.

Table 3 ELEMENTAL HEAT LOSS METHOD
Maximum area of openings for average U-value of 2. (W/m²K)

Building type	Windows and doors as % of the area of exposed wall	Rooflights as % of area of roof
Residential buildings (where people temporarily or permanently reside)	30	20
Places of assembly, offices and shops	40	20
Industrial and storage buildings	15	20

NOTES:

- 1 For the purposes of this calculation, dormer windows in a roof may be included in the rooflight area.
- 2 Opening area excludes area of openings for vehicle access doors and display windows and similar glazing.

1.2.3.3 In applying [Table 3](#) to an extension to an existing building, the relevant wall and roof areas may be taken to be:

- (a) the combined areas for the existing building and extension; in this case the combined area of external door and window openings refers to the area of such openings in the extended building, i.e. the opening area of retained external doors, windows together with the opening area of external doors, windows in the extension; or
- (b) the floor area of the extension alone; in this case the combined area of external doors, window and rooflight openings refers to the area of such openings in the extension alone. In this case the maximum combined area of external door, window and rooflight openings derived using [Table 3](#) can be increased by an area equivalent to the area of external door, window and rooflight openings of the existing building which have been closed or covered over by the extension.

For extensions which

- are thermally separated from the adjacent spaces within the building by walls, doors and

other opaque or glazed elements which have U-values not more than 10% greater than corresponding exposed areas of the main building, and

- are unheated or, if provided with a heating facility, have provision for automatic temperature and on-off control independent of the heating provision in the existing building,

the limitation on the combined area of exposed external door, window and rooflight openings does not apply. In this case the average U-value of these elements should not exceed the value of 2.2 W/m²K.

1.2.3.4 There is a wide range of possible designs for external doors, windows and rooflights. Certified U-values should be used, where available. In the absence of certified data, U-values should be calculated in accordance with I.S. EN ISO 10077-1: 2000 or I.S. EN ISO 10077-2: 2000, as appropriate (See Appendix A). Alternatively, the indicative U-values for these components given in [Table B24](#) can be used (see [Appendix B](#)).

1.2.3.5 [Diagram 2](#) summarises the fabric insulation standards and allowances applicable in the Elemental Heat Loss method.

1.2.4 THERMAL BRIDGING

1.2.4.1 To avoid excessive heat losses and local condensation problems, provision should be made to limit local thermal bridging, e.g. around windows, doors and other wall openings, at junctions between elements and at other locations. Any thermal bridge should not pose a risk of surface or interstitial condensation and any excessive increase in heat loss associated with the thermal bridge should be taken account of in the calculation of average U-value.

The additional heat loss associated with thermal bridges should be limited to less than 16% of the total calculated heat loss through the plane building elements.

Paragraphs 1.2.4.2. and 1.2.4.3 give guidance on the limitation of thermal bridging for typical locations in conventional construction. Alternatively Appendix D gives information on the calculation procedure

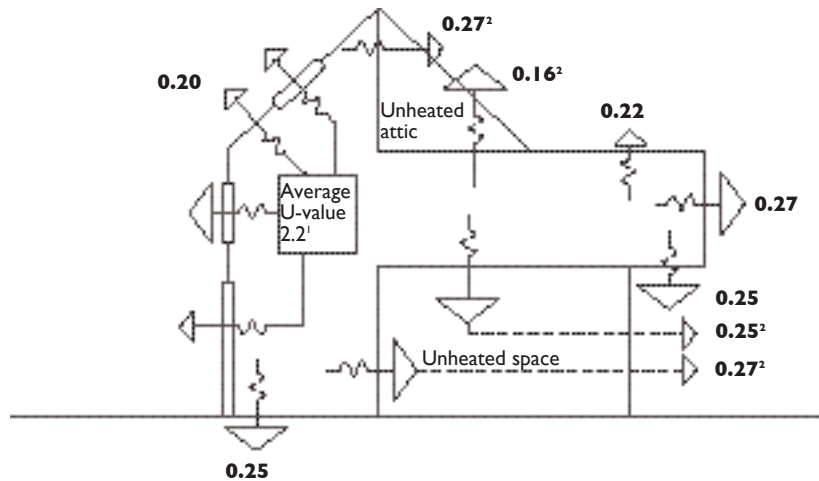

NOTES

1. Windows, doors and rooflights should have maximum U-value of 2.2 W/m²K and maximum opening area as set out in Table 6. However areas and U-values may be varied provided the total heat loss through these elements is not increased.
2. The U-value includes the effect of unheated voids or other spaces.

which can be used for the calculation of linear thermal transmittance of key junctions.

See Appendix D for further information in relation to thermal bridging and its effect on building heat loss.

1.2.4.2 Use of cill, jamb lintel and junction details set out in-

- (a) "Right on the Site Issue No. 28", published by HomeBond;
- (b) "Limiting Thermal Bridging and Air Infiltration: Acceptable Construction Details" available on www.environ.ie
- (c) other published details which have been assessed as satisfying the guidance in relation to Temperature Factor and Linear Thermal Transmittance set out in Appendix D, should represent reasonable provision to limit thermal bridging.
- (d) designs similar to those shown in Diagram 3. At lintels, jambs and cills 15 mm thickness of insulation material having λ -values of 0.04 W/mK (or equivalent) will generally be adequate.

1.2.4.3 Care should be taken to control the risk of thermal bridging at the edges of floors. All slab-on-ground floors should be provided with edge insulation to the vertical edge of the slab at all external and internal walls. The insulation should have minimum thermal resistance of 0.7 m²K/W (25 mm of insulation with thermal conductivity of 0.035 W/mK, or equivalent).

Some large floors may have an acceptable average U value without the need for added insulation. However, perimeter insulation should always be provided. Perimeter insulation should extend at least 0.5 m vertically or 1 m horizontally. Where the perimeter insulation is placed horizontally, insulation to the vertical edge of the slab should also be provided as indicated above.

1.2.4.4 For new buildings the Heat Loss associated with thermal bridges is taken into account in calculating energy use and CO₂ emissions in the NEAP framework.

Where the details used are as described in 1.2.4.2 (a), (c) or (d) and 1.2.4.3 the psi values given in Table D1, Appendix D may be used for the NEAP calculation. Where the details used are those in 1.2.4.2 (b) the psi values given in Table D2 in Appendix D may be used.

Diagram 3
Lintel, jamb and sill designs

Para 1.2.4.2

LINTELS

JAMBS

CILLS

HEAT LOSS PATHS
 without insulation

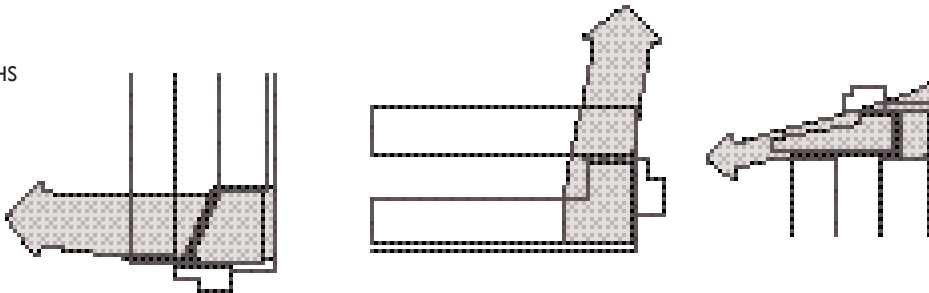

INTERNAL INSULATION

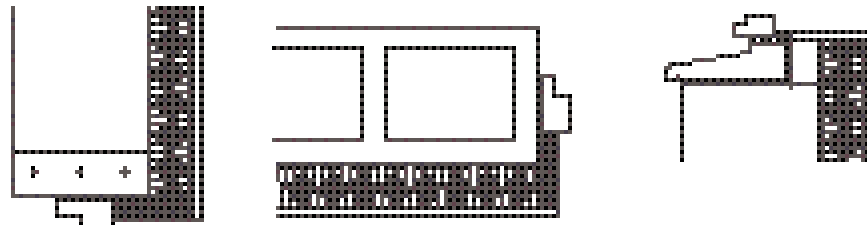

PARTIAL CAVITY FILL

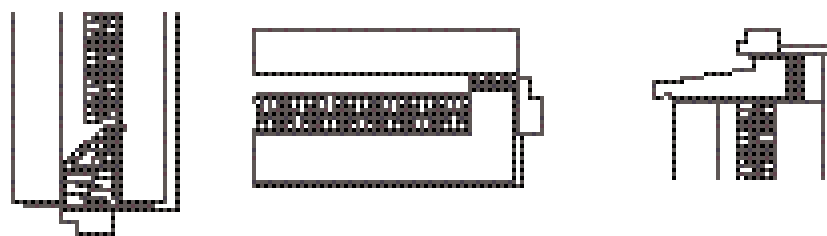

FULL CAVITY FILL

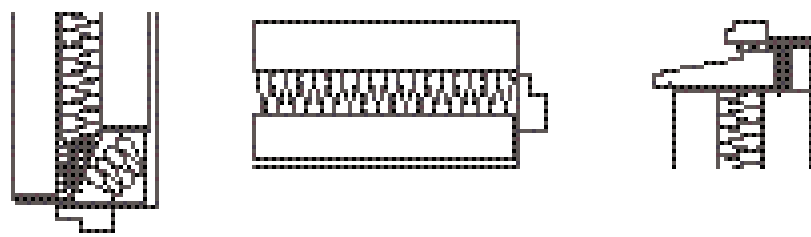

NOTE

- I. The internal faces of metal lintels should be covered with at least 15 mm of lightweight plaster; alternatively they can be dry-lined.

1.2.5 AIR INFILTRATION

1.2.5.1 Infiltration of cold outside air should be limited by reducing unintentional air paths as far as is practicable. A reasonably continuous air barrier should be provided over the whole thermal envelope, including elements separating the building from adjoining heated or unheated areas.

1.2.5.2 For conventional construction measures taken to ensure this should include:

- (a) sealing the void between dry-lining and masonry walls at the edges of openings such as windows and doors, and at the junctions with walls, floors and ceilings (e.g. by continuous bands of bonding plaster or battens),
- (b) sealing vapour control membranes in timber-frame constructions,
- (c) fitting draught-stripping in the frames of openable elements of windows, doors and rooflights,
- (d) sealing around access or service hatches which provide access to unheated voids (loft spaces) from the conditioned space,
- (e) ensuring ducting for concealed services is sealed at floor and ceiling levels and sealing piped services where they penetrate or project into hollow constructions or voids.

Diagram 4 illustrates some of these measures.

1.2.5.3 Additional guidance on appropriate measures to limit air infiltration in larger office and commercial buildings is given in BRE Report BR 448, *Air tightness in commercial and public buildings*. Guidance on methods to limit air infiltration through twin skin metal cladding and roofing systems is contained in Steel Construction Institute (SCI) Technical Information Sheet No. 311, *The design of twin-skin metal cladding*.

1.2.5.4 Air permeability can be measured by means of pressure testing of a building prior to completion. The procedure for testing is specified in IS EN 13829: 2000 “*Thermal performance of buildings: determination of air permeability of buildings: fan pressurisation method*”. Additional guidance on testing procedure is given in CIBSE Technical Manual TM 23 “*Testing Buildings for Air leakage*” and BRE document

BR 448 *Tightness in Commercial and Public Buildings*.

1.2.5.5 Care should be taken to ensure that measures to limit air infiltration do not negatively affect compliance with the ventilation requirements of Part F and Part J.

1.2.6 AVOIDING SOLAR OVERHEATING

1.2.6.1 Buildings should be designed and constructed so that:

- (a) those occupied spaces that rely on natural ventilation do not risk unacceptable levels of thermal discomfort due to overheating caused by solar gain, and
- (b) those spaces that incorporate mechanical ventilation or cooling do not require excessive plant capacity to maintain the desired space conditions.

Where extensive use of glazing is proposed in the building design, particular care should be exercised to ensure compliance with this aspect of the Regulations.

1.2.6.2 Alternative approaches to showing compliance include:

- (a) showing that the average daily solar heat load per unit floor area during the period of occupancy would not be greater than 25 W/m², when the average solar load for glazing of different orientations is taken to be as specified in Table 4. The calculation procedure given in Appendix E can be used to do this. Local weather data averaged over a

Table 4 Average solar load between 7.30 and 17.30 for different glazing orientations	
Orientation	Average solar load (W/m ²)
N	125
NE/NW	160
E/W	205
SE/SW	198
S	156
Horizontal	327

NOTE 1: This solar load is not likely to be exceeded on more than 2.5% of days in July. Source: CIBSE Guide A, Section 5.

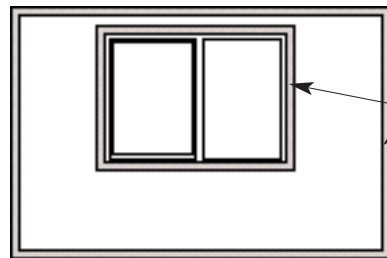

1. POSITION OF CONTINUOUS SEALING BANDS FOR DRY-LININGS FIXED TO MASONRY WALLS

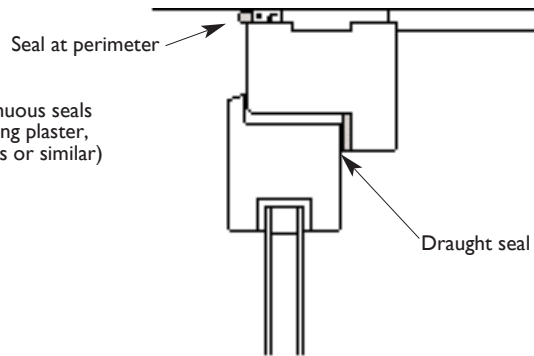

2. SEALING AT WINDOWS AND DOORS

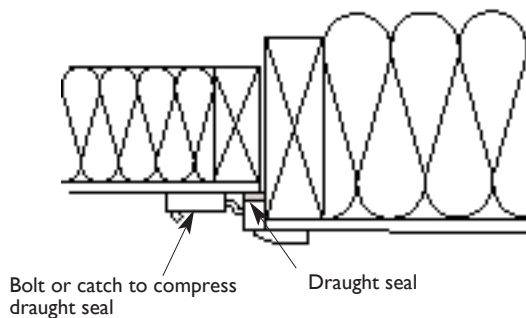

3. SEALING ACCESS HATCH

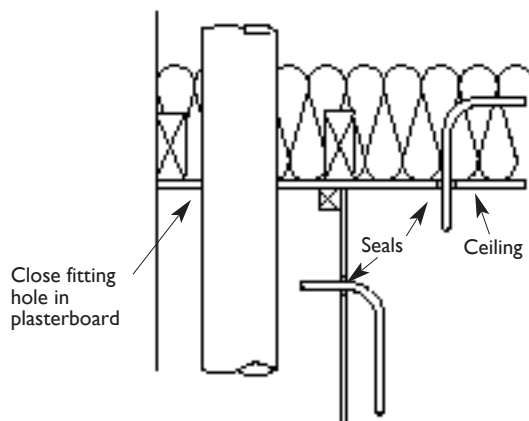

4. SEALING AROUND SERVICE PIPES

period of 15 years, at least, can be used instead of the data given in [Table 4](#), where available.

- (b) showing by detailed calculation procedures such as those described in chapter 5 of CIBSE Guide A, that in the absence of mechanical cooling or mechanical ventilation, the space temperature will not exceed 28°C for an unacceptable proportion of the period of occupation. The period for which this temperature can be exceeded depends on the nature of occupancy and the activities within the space. For offices and similarly occupied buildings, a guide figure is 20 hours per annum during the period of occupancy. A range of computer simulation programs exists that facilitate this calculation.

1.2.6.3 Measures that can be effective in reducing the risk of solar overheating include:

- (a) using glazing designed to reduce solar gains while not unduly limiting natural light transmittance,
- (b) the incorporation of passive measures such as shading (detailed guidance in this regard is given in BRE Report No 364, *Solar shading of buildings*), and
- (c) the use of exposed thermal capacity combined with night ventilation (detailed guidance in this regard is given in Action Energy General Information Report 31 (GIR031) *Avoiding or minimizing the use of air-conditioning*).

1.3: Building Services

1.3.1 HEATING PLANT EFFICIENCY

Heating plant should be designed and installed so that it operates efficiently over the range of loading likely to be encountered. Oil and gas fired boilers should satisfy the efficiency requirements specified in S.I. No. 260 of 1994: *European Communities (Efficiency requirements for new hot water boilers fired with liquid or gaseous fuels) Regulations, 1994*.

1.3.2 CONTROLS FOR SPACE HEATING AND HOT WATER SUPPLY SYSTEMS

1.3.2.1 Space and water heating systems should be effectively controlled so as to limit energy use by these systems to that required to satisfy user requirements and, where appropriate, to protect the building and its contents from damage due to low temperatures. This section is not intended to apply to control systems for commercial and industrial processes.

1.3.2.2 Buildings should be provided with zone, timing and temperature controls such that, for space heating, each functional area is maintained at the required temperature only during the period when it is occupied. Additional space heating controls may be provided to allow heating during extended unusual occupation hours and to provide for sufficient background heating to prevent condensation or frost damage when the heating system would otherwise be switched off.

1.3.2.3 Hot water systems should be designed and provided with appropriate controls so that they can be operated efficiently. For efficient operation, hot water systems should not be over-sized and should be designed to avoid low-load operation of heating plant. The layout should minimize the length of circulation loops and minimize the length and diameter of dead legs. Designers should have particular regard to the need to limit the risk of promoting the growth of legionella bacteria. Local instantaneous heaters should be used, where appropriate. Consideration should be given to the use of renewable energy, e.g. solar water heating, and to heat recovery from other processes, where applicable. Electric water heating should be avoided except where demand is low.

1.3.2.4 Effective control of space and water heating can be achieved as follows:

- (a) in buildings with a heating system of maximum output not exceeding 100 kW, by following the guidance in Action Energy Good Practice Guide 132 (GPG132) *Heating Controls in small commercial and multi-residential buildings* published by BRECSU;
- (b) in larger or more complex buildings, by following the guidance contained in CIBSE Guide H: *Building Control Systems* published by CIBSE.

1.3.3 AIR CONDITIONING AND MECHANICAL VENTILATION (ACMV)

1.3.3.1 Buildings that use ACMV systems to treat in excess of 200 m² floor area should be designed and constructed such that:

- (a) the form and fabric of the building do not result in a requirement for excessive installed capacity of ACMV equipment. In particular, the suitable specification of glazing ratios and solar shading are an important way to limit cooling requirements (see Section 1.2.6 above).
- (b) components such as fans, pumps and refrigeration equipment are reasonably efficient and appropriately sized so as to have no more capacity for demand and standby than is necessary for the task.
- (c) suitable facilities are provided to manage, control and monitor the operation of the equipment and the systems.

1.3.3.2 ACMV systems can be considered to be adequately sized if the specific fan power (SFP) is less than the values given in the following sub-paragraphs. The SFP is the sum of the design total circuit-Watts of all fans that supply air and exhaust it back to outdoors (i.e., the sum of supply and extract fans), including all losses through switchgear and controls such as inverters, divided by the design ventilation rate through the building.

-
- (a) For ACMV systems in new buildings, the SFP should be no greater than 2.0 W/litre/second.
 - (b) For new ACMV systems in refurbished buildings, or where an existing ACMV system in an existing building is being substantially altered, the SFP should be no greater than 3.0 W/litre/second.

1.3.3.3 These SFP values are appropriate for typical ventilated spaces intended for human occupancy. Where specialist processes are involved or external pollution levels exceed those normally encountered and, as a result, greater levels of filtration or air cleaning are required, higher SFPs may be appropriate. In the context of this section “specialist processes” can be taken to include any activity which is not typical of the particular building use, which affects a significant area within the building, and where the resulting need for heating, ventilation or air conditioning is significantly different to that typical for the building. When assessing the performance of ACMV systems, areas where the existence or sizing of these systems is determined by process requirements should be excluded from the considered area, together with the plant capacity, or proportion of the plant capacity, that is provided to service those areas. Activities and areas in office buildings considered to represent process requirements would include:

- Staff restaurants and kitchens;
- Large dedicated conference rooms;
- Sports facilities;
- Dedicated computer or communications rooms.

1.3.3.4 Mechanical ventilation systems should be reasonably efficient at part load. This can be achieved by providing efficient variable flow control systems incorporating, for instance, variable speed drives or variable pitch axial fans. More detailed guidance is given in Action Energy General Information, Report 41 (GIR041) *Variable flow control, General Information*, published by BRECSU.

1.3.4 INSULATION OF STORAGE VESSELS, PIPES AND DUCTS

1.3.4.1 This section only applies to pipes, ducts and vessels for the provision of space heating, space

cooling (including chilled water and refrigerant pipe work) and hot water supply for normal occupation. It does not apply to pipes, ducts and vessels associated with commercial or industrial processes.

1.3.4.2 Hot water storage vessels, pipes and ducts associated with the provision of heating and hot water in a building should be insulated to limit heat loss, except where the heat flow through the wall of the pipe, duct or vessel is always useful in conditioning the surrounding space. Storage vessels for chilled water and refrigerant, and pipes and ducts that serve air-conditioning systems should be insulated to limit heat gain from the surrounding environment.

1.3.4.3 Provision of insulation to pipes, ducts and storage vessels, in accordance with the standards specified in BS 5422: 2001, should adequately limit heat loss or heat gain, as appropriate. The appropriate insulation level for storage vessels should be taken as that given in BS 5422: 2001 for flat surfaces.

1.3.4.4 It should be noted that water pipes and storage vessels in unheated areas will generally need to be insulated for the purpose of protection against freezing. Guidance on suitable protection measures is given in BRE Report 262, *Thermal insulation: avoiding risks*.

1.3.5 ARTIFICIAL LIGHTING

1.3.5.1 The guidance given in Paragraphs 1.3.5.2 and 1.3.5.3 below need not be applied when the total installed lighting capacity is less than 1000 W. In this section the term “efficacy” is used to describe the energy efficiency of a lamp. It is described by the amount of light it produces in lumens with respect to the power it consumes in Watts.

1.3.5.2 General purpose artificial lighting systems shall be designed and controlled so as to ensure the efficient use of energy for this purpose. The efficiency of a general lighting system may be considered acceptable if it complies with one of the following:

- (a) 95 % of the artificial lighting capacity in circuit Watts is provided by lighting fittings which use

lamps with luminous efficacies not less than those of the types listed in [Table 5](#);

- (b) the installed lighting capacity comprises lighting fittings with lamps having an average initial (100 hour) efficacy of not less than 65 lumens per circuit Watt; or
- (c) the lighting design is in accordance with the guidance in the “Code for Lighting” published by CIBSE, in particular the guidance on energy efficiency in Section 2.4 of that document.

1.3.5.3 The aim of lighting controls should be to encourage the maximum use of daylight and to avoid unnecessary artificial lighting, particularly when spaces are unoccupied, having regard to the need to ensure that the operation of automatically switched lighting systems does not endanger occupants in a building. In this section reference to switches includes dimmer switches and switching includes dimming.

Adequate control depends on the nature and use pattern of the building. This may be achieved by one, or more, of the following means, used alone or in combination, as appropriate:

- (a) local manually operated switches in easily accessible positions within each working area or at boundaries between working areas and general circulation routes. The distance on plan from any local switch to the luminaries it controls should generally be not more than eight metres, or three times the height of the light fitting above the floor if this is greater;
- (b) daylight-linked photo-electric switching or dimming for lighting adjacent to windows or other sources of natural light;
- (c) remote controlled switches operated by infra red transmitter, sonic, ultrasonic or telephone handset controls;
- (d) automatic switching systems which switch the lighting off when they sense the absence of occupants;
- (e) time-controlled switches.

For offices and storage buildings, local switching, either manual or remote controlled, is desirable. For some other building uses, e.g. where continuous lighting is required during hours of operation, time switching or daylight-linked photo-electric switching may be more appropriate.

Table 5 Light sources suitable for general lighting

Light source	Types and rating
High pressure Sodium	All types and ratings
Metal halide	All types and ratings
Induction lighting	All types and ratings
Tubular fluorescent	26 mm diameter (T8) lamps, and 16 mm diameter (T5) lamps rated above 11W, provided with high efficiency control gear. 38 mm diameter (T12) linear fluorescent lamps 2400 mm in length
Compact fluorescent	All ratings above 11W
Other	Any type and rating with an efficacy greater than 50 lumens per circuit Watt.

APPENDICES

Appendix A: Calculation of U-Values

GENERAL

AI.1 General Guidance on the Calculation of U-values is contained in Report BR 443 “Conventions for U-value Calculations” 2006. For building elements and components generally, the method of calculating U-values is specified in I.S. EN ISO 6946: 1997. U-values of components involving heat transfer to the ground, e.g. ground floors with or without floor voids, basement walls, are calculated by the method specified in I.S. EN ISO 13370: 1999. A soil thermal conductivity of 2.0 W/mK should be used, unless otherwise verified. U-values for windows, doors and shutters may be calculated using I.S. EN ISO 10077-1: 2000 or I.S. EN ISO 10077-2: 2000. Information on U-values and guidance on calculation procedures contained in the 1999 edition of CIBSE Guide A3: Thermal Properties of Building Structures are based on these standards and may be used to show compliance with this Part.

A method for assessing U-values of light steelframed constructions is given in Digest 465 “U-values for light steel frame construction”, published by BRE. Guidance in relation to the calculation of U-values for various forms of metal clad construction can be found in Technical Paper No. 14 “Guidance for the design of metal roofing and cladding to comply with Approved Document L2: 2001” published by MCRMA, Technical Information Sheet No. 312, “Metal cladding: U-value calculation assessing thermal performance of built-up metal roof and wall cladding systems using rail and bracket spacers” published by SCI and IP 10/02 “Metal cladding: assessing thermal performance of built-up systems which use ‘Z’ spacers” published by BRE.

AI.2 U-values derived by calculation should be rounded to two significant figures and relevant information on input data should be provided. When calculating U-values the effects of timber joists, structural and other framing, mortar bedding, window frames and other small areas where thermal bridging occurs must be taken into account. Similarly, account must be taken of the effect of small areas where the insulation level is reduced significantly relative to the general level for the component or structure element under consideration. Thermal bridging may be disregarded, however, where the general thermal resistance does not exceed that in the bridged area by more than 0.1 m²K/W. For example, normal mortar joints need not be taken

into account in calculations for brickwork or concrete blockwork where the density of the brick or block material is in excess of 1500 kg/m³. A ventilation opening in a wall or roof (other than a window, rooflight or door opening), may be considered as having the same U-value as the element in which it occurs.

AI.3 Examples of the application of the calculation method specified in I.S. EN 6946: 1997 are given below. An example of the calculation of ground floor U-values using I.S. EN ISO 13370: 1999 is also given.

AI.4 Thermal conductivities of common building materials are given in [Table A1](#) and for common insulating materials in [Table A2](#). For the most part, these are taken from I.S. EN 12524: 2000 or CIBSE Guide A3. See Paragraph 0.3.3 regarding application of these Tables.

SIMPLE STRUCTURE WITHOUT THERMAL BRIDGING

A2.1 To calculate the U-value of a building element (wall or roof) using I.S. EN ISO 6946: 1997, the thermal resistance of each component is calculated, and these thermal resistances, together with surface resistances as appropriate, are then combined to yield the total thermal resistance and U-value. The result is corrected to account for mechanical fixings (e.g. wall ties) or air gaps if required. For an element consisting of homogenous layers with no thermal bridging, the total resistance is simply the sum of individual thermal resistances and surface resistances.

I.S. EN 6946: 1997 provides for corrections to the calculated U-value. In the case of example AI (see [Diagram AI](#)), corrections for air gaps in the insulated layer and for mechanical fasteners may apply. However, if the total correction is less than 3% of the calculated value, the correction may be ignored.

In this case no correction for air gaps applies as it is assumed that the insulation boards meet the dimensional standards set out in I.S. EN ISO 6946: 1997 and that they are installed without gaps greater than 5 mm. The construction involves the use of wall ties that penetrate fully through the insulation layer.

Table A1

Thermal conductivity of some common building materials

Material	Density (kg/m ³)	Thermal Conductivity (W/mK)
General Building Materials		
Clay Brickwork (outer leaf)	1,700	0.77
Clay Brickwork (inner leaf)	1,700	0.56
Concrete block (heavyweight)	2,000	1.33
Concrete block (medium weight)	1,400	0.57
Concrete block (autoclaved aerated)	600	0.18
Concrete block (autoclaved aerated)	350	0.08
Cast concrete, high density	2,400	2.00
Cast concrete, medium density	1,800	1.15
Aerated concrete slab	500	0.16
Concrete screed	1,200	0.41
Reinforced concrete (1% steel)	2,300	2.30
Reinforced concrete (2% steel)	2,400	2.50
Wall ties, stainless steel	7,900	17.00
Wall ties, galvanised steel	7,800	50.00
Mortar (protected)	1,750	0.88
Mortar (exposed)	1,750	0.94
External rendering (cement sand)	1,300	0.57
Plaster (gypsum lightweight)	600	0.18
Plaster (gypsum)	1,200	0.43
Plasterboard	900	0.25
Natural Slate	2,500	2.20
Concrete tiles	2,100	1.50
Clay tiles	2,000	1.00
Fibre cement slates	1,800	0.45
Ceramic tiles	2,300	1.30
Plastic tiles	1,000	0.20
Asphalt	2,100	0.70
Felt bitumen layers	1,100	0.23
Timber, softwood	500	0.13
Timber, hardwood	700	0.18
Wood wool slab	500	0.10
Wood-based panels (plywood, chipboard, etc.)	500	0.13
NOTE: The values in this table are indicative only. Certified values, should be used in preference, if available.		

Table A2

Thermal conductivity of some common insulation materials

Material	Density (kg/m ³)	Thermal Conductivity (W/mK)
Insulation		
Expanded polystyrene (EPS) slab (HD)	25	0.035
Expanded polystyrene (EPS) slab (SD)	15	0.037
Extruded polystyrene	30	0.025
Glass fibre / wool quilt	12	0.040
Glass fibre / wool batt	25	0.035
Phenolic foam	30	0.025
Polyurethane board	30	0.025
NOTE: The values in this table are indicative only. These may be used for early design purposes. Certified values, taking ageing into account, where appropriate, should be used in final calculations (see para. 0.3.2.)		

Example A1: Masonry cavity wall

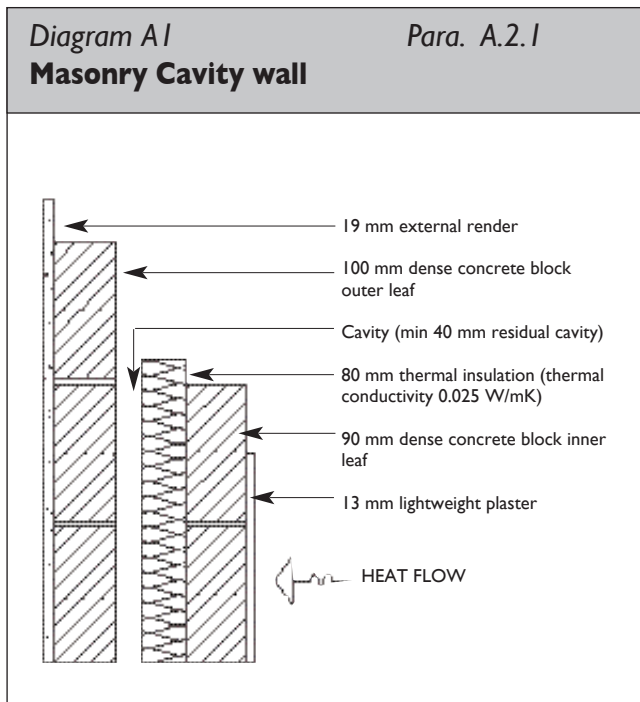

Layer/Surface	Thickness (m)	Conductivity (W/mK)	Resistance (m ² K/W)
External surface	----	----	0.040
External render	0.019	0.57	0.033
Concrete Block	0.100	1.33	0.075
Air cavity	----	----	0.180
Insulation	0.080	0.025	3.200
Concrete Block	0.100	1.33	0.075
Plaster (lightweight)	0.013	0.18	0.072
Internal surface	----	----	0.130
Total Resistance	----	----	3.805
U-value of construction = 1/3.805 = 0.26 W/m²K			

A potential correction factor applies which, assuming the use of 4 mm diameter stainless steel ties at 5 ties per m², is calculated as 0.006 W/m²K. This is less than 3% of the calculated U-value and may be ignored. It should be noted that, if galvanised steel wall ties were used, a correction of 0.02 W/m²K would apply, and the corrected U-value for this construction would be 0.28 W/m²K.

STRUCTURE WITH BRIDGED LAYER(S)

A2.2 For an element in which one or more layers are thermally bridged, the total thermal resistance is calculated in three steps as follows.

- The upper thermal resistance is based on the assumption that heat flows through the component in straight lines perpendicular to the element's surfaces. To calculate it, all possible heat flow paths are identified, for each path the resistance of all layers are combined in series to give the total resistance for the path, and the resistances of all paths are then combined in parallel to give the upper resistance of the element.
- The lower thermal resistance is based on the assumption that all planes parallel to the surfaces of the component are isothermal surfaces. To calculate it, the resistances of all components of each thermally bridged layer are combined in parallel to give the effective resistance for the layer, and the resistances of all layers are then combined in series to give the lower resistance of the element.
- The total thermal resistance is the mean of the upper and lower resistances.

Example A2: Timber-frame wall (with one insulating layer bridged)

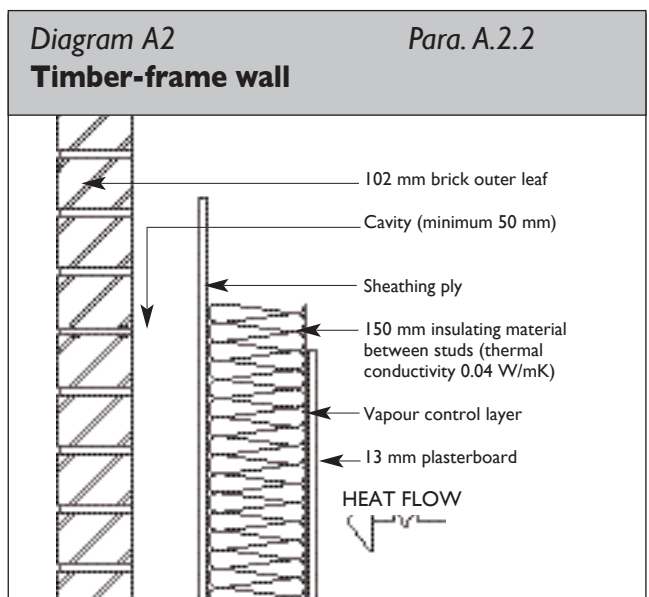

The thermal resistance of each component is calculated (or, in the case of surface resistances, entered) as follows:

Layer/Surface	Thickness (m)	Conductivity (W/mK)	Resistance (m ² K / W)
External surface	---	---	0.040
Brick outer leaf	0.102	0.77	0.132
Air cavity	---	---	0.180
Sheathing ply	0.012	0.13	0.092
Mineral wool insulation	0.150	0.04	3.750
Timber studs	0.150	0.13	1.154
Plasterboard	0.013	0.25	0.052
Internal surface	---	---	0.130

Upper resistance

Assuming that heat flows in straight lines perpendicular to the wall surfaces, there are two heat flow paths - through the insulation and through the studs. The resistance of each of these paths is calculated as follows.

Resistance through section containing insulation [m² K / W]:

External surface resistance	0.040
Brick outer leaf	0.132
Air cavity	0.180
Sheathing ply	0.092
Mineral wool insulation	3.750
Plasterboard	0.052
Internal surface resistance	<u>0.130</u>
Total	4.376

Resistance through section containing timber stud [m² K / W]

External surface resistance	0.040
Brick outer leaf	0.132
Air cavity	0.180
Sheathing ply	0.092
Timber studs	1.154
Plasterboard	0.052
Internal surface resistance	<u>0.130</u>
Total	1.780

The upper thermal resistance R_u is obtained from:

$$R_u = 1 / (F_1 / R_1 + F_2 / R_2)$$

where F_1 and F_2 are the fractional areas of heat flow paths 1 and 2, and R_1 and R_2 are the resistances of these paths.

$$\text{Upper resistance } R_u = 1 / (0.85 / 4.377 + 0.15 / 1.781) = 3.592 \text{ m}^2 \text{ K / W}$$

Lower resistance

Assuming an isothermal plane on each face of the layer of insulation which is bridged by timber studs, the thermal resistance of this bridged layer, R_b , is calculated from

$$R_b = 1 / (F_{ins} / R_{ins} + F_t / R_t)$$

where F_{ins} and F_t are the fractional areas of insulation and timber, and R_{ins} and R_t are their resistances.

$$R_b = 1 / (0.85 / 3.750 + 0.15 / 1.154) = 2.804 \text{ m}^2 \text{ K / W}$$

The resistances of all layers are then combined in series to give the lower resistance [m² K / W]

External surface resistance	0.040
Brick outer leaf	0.132
Air cavity	0.180
Bracing board	0.092
Bridged insulation layer	2.804
Plasterboard	0.052
Internal surface resistance	<u>0.130</u>

Lower resistance (R_l) 3.430

Total resistance

The total resistance R_t is given by:

$$R_t = (R_u + R_l) / 2 = (3.59 + 3.431) / 2 = 3.511 \text{ m}^2 \text{ K / W}$$

The U-value is the reciprocal of the total resistance:

$$U\text{-value} = 1 / 3.511 = 0.28 \text{ W/m}^2\text{K (to 2 decimal places)}$$

There is a potential correction for air gaps in the insulation layer. I.S. EN ISO 6946: 1997 gives a U-value correction of 0.0065 W/m²K for this construction. This is less than 3% of the calculated U-value and can be ignored.

Example A3: Pitched roof with insulation at ceiling level (between and over joists).

A pitched roof has 100 mm of mineral wool tightly fitted between 44 mm by 100 mm timber joists spaced 600 mm apart (centres to centres) and 150 mm of mineral wool over the joists. The roof is slated or tiled with sarking felt under the slates or tiles. The ceiling consists of 13 mm of plasterboard. The fractional area of timber at ceiling level is taken as 8%.

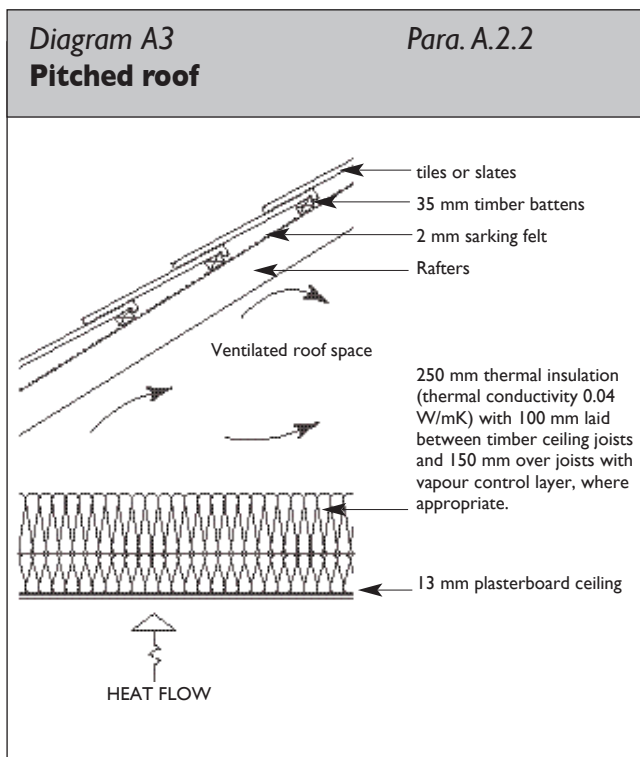

Layer/Surface	Thickness (m)	Conductivity (W/mK)	Resistance (m ² K/W)
External surface	-	-	0.040
Roof space (including sloping construction and roof cavity)	-	-	0.200
Mineral wool (continuous layer)	0.150	0.04	3.750
Mineral wool (between joists)	0.100	0.04	2.500
Timber joists	0.100	0.13	1.154
Plasterboard	0.013	0.25	0.052
Internal surface	-	-	0.100

Upper resistance (R_u)

Resistance through section containing both layers of insulation [m²K/W]

External surface resistance	0.040
Resistance of roof space	0.200
Resistance of mineral wool over joists	3.750
Resistance of mineral wool between joists	2.500
Resistance of plasterboard	0.052
Inside surface resistance	<u>0.100</u>

Total **6.642**

Resistance through section containing timber joists

External surface resistance	0.040
Resistance of roof space	0.200
Resistance of mineral wool over joists	3.750
Resistance of timber joists	0.769
Resistance of plasterboard	0.052
Inside surface resistance	<u>0.100</u>

Total **4.911**

The upper thermal resistance [R_u] is obtained from:

$$R_u = 1 / (F_1 / R_1 + F_2 / R_2)$$

where F₁ and F₂ are the fractional areas of heat flow paths 1 and 2, and R₁ and R₂ are the resistances of these paths.

$$\text{Upper resistance } R_u = 1 / (0.92 / 6.642 + 0.08 / 4.911) = 6.460 \text{ m}^2 \text{ K/W}$$

Lower resistance (R_l)

Assuming an isothermal plane on each face of the layer of insulation which is bridged by timber studs, the thermal resistance of this bridged layer, R_b, is calculated from

$$R_b = 1 / (F_{ins} / R_{ins} + F_t / R_t)$$

where F_{ins} and F_t are the fractional areas of insulation and timber, and R_{ins} and R_t are their resistances.

$$R_b = 1 / (0.92 / 2.500 + 0.08 / 0.769) = 2.119 \text{ m}^2 \text{ K/W}$$

The resistances of all layers are then combined in series to give the lower resistance [$\text{m}^2\text{K}/\text{W}$]

External surface resistance	0.040
Resistance of roof space	0.200
Resistance of mineral wool over joists	3.750
Resistance of bridged layer	2.119
Resistance of plasterboard	0.052
Inside surface resistance	<u>0.100</u>

Lower resistance (R_l) **6.261**

Total resistance

The total resistance R_t is given by:

$$R_t = (R_u + R_l) / 2 = (6.460 + 6.261) / 2 = 6.361 \text{ m}^2\text{K}/\text{W}$$

The U-value is the reciprocal of the total resistance:

$$\mathbf{U\text{-value} = 1 / 6.361 = 0.16 \text{ W}/\text{m}^2\text{K}}$$
 (to 2 decimal places).

I.S. EN ISO 6946: 1997 does not specify any potential correction for this construction.

GROUND FLOORS AND BASEMENTS

A3.1 The U-value of an uninsulated ground floor depends on a number of factors including floor shape and area and the nature of the soil beneath the floor. I.S. EN ISO 13370: 1999 deals with the calculation of U-values of ground floors. Methods are specified for floors directly on the ground and for floors with vented and unvented sub-floor spaces. I.S. EN ISO 13370: 1999 also covers heat loss from basement floors and walls.

A3.2 In the case of semi-detached or terraced premises, blocks of flats and similar buildings, the floor dimensions can be taken as either those of the individual premises or those of the whole building. Unheated spaces outside the insulated fabric, such as attached porches or garages, should be excluded when deriving floor dimensions but the length of the floor perimeter between the heated building and the unheated space should be included when determining the length of exposed perimeter. Where such ancillary areas have the potential to become part of the occupied area of the building floors should be insulated to the same level as the building floors unless it is envisaged that a new insulated floor will be provided when converted.

Example A4: Slab-on-ground floor – full floor insulation.

The slab-on-ground floor consists of a 150 mm dense concrete ground floor slab on 100 mm insulation. The insulation has a thermal conductivity of 0.035 W/mK. The floor dimensions are 8750 mm by 7250 mm with three sides exposed. One 8750 mm side abuts the floor of an adjoining semi-detached house.

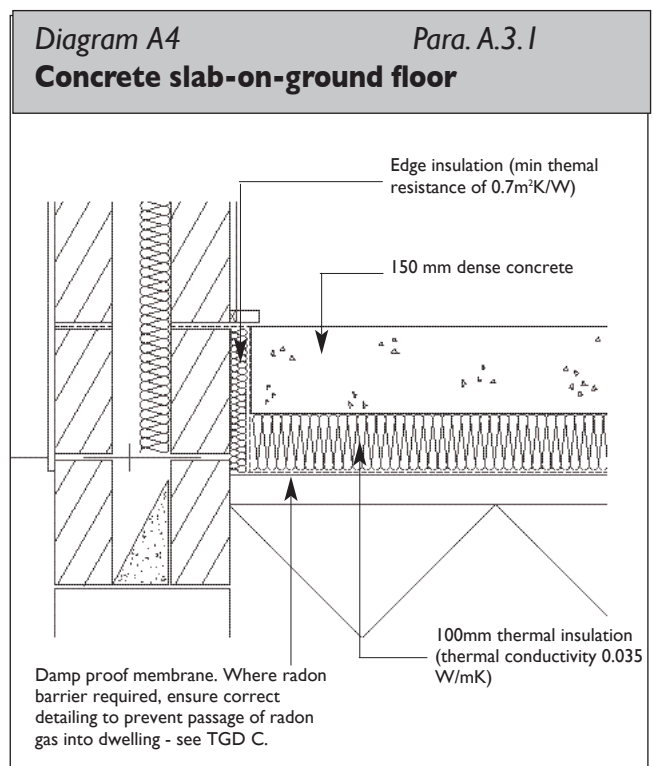

In accordance with I.S. EN ISO 13370: 1999, the following expression gives the U-value for well-insulated floors:

$$U = \frac{\lambda}{(0.457B' + d_t)}, \text{ where}$$

λ = thermal conductivity of unfrozen ground (W/mK)
 B' = $2A/P$ (m)
 d_t = $w + \lambda(R_{si} + R_f + R_{se})$ (m)
 A = floor area (m²)
 P = heat loss perimeter (m)
 w = wall thickness (m)

R_{si} , R_f and R_{se} are internal surface resistance, floor construction (including insulation) resistance and external surface resistance respectively. Standard values of R_{si} and R_{se} for floors are given as 0.17 m²K/W and 0.04 m²K/W respectively. The standard also states that the thermal resistance of dense concrete slabs and thin floor coverings may be ignored in the calculation and that the thermal conductivity of the ground should be taken as 2.0 W/mK unless otherwise known or specified.

Ignoring the thermal resistance of the dense concrete slab, the thermal resistance of the floor construction (R_f) is equal to the thermal resistance of the insulation alone, i.e. 0.1/0.035 or 2.857 m²K/W. Taking the wall thickness as 300 mm, this gives

$$d_t = 0.30 + 2.0(0.17 + 2.857 + 0.04) = 6.434 \text{ m.}$$

Also $B' = \frac{2(8.75 \times 7.25)}{(8.75 + 7.25 + 7.25)} = 5.457 \text{ m}$

Therefore $U = \frac{2.0}{((0.457 \times 5.457) + 6.434)} = 0.22 \text{ W/m}^2\text{K.}$

The edge insulation to the slab is provided to prevent thermal bridging at the edge of the slab. I.S. EN ISO 13370: 1999 does not consider this edge insulation as contributing to the overall floor insulation and thus reducing the floor U-value. However, edge insulation, which extends below the external ground level, is considered to contribute to a reduction in floor U-value and a method of taking this into account is included in the standard. Foundation walls of insulating lightweight concrete may be taken as edge insulation for this purpose.

ELEMENTS ADJACENT TO UNHEATED SPACES

A4.1 As indicated in Paragraph 0.3.5, the procedure for the calculation of U-values of elements adjacent to unheated spaces (previously referred to as semi-exposed elements) is given in I.S. EN ISO 6946: 1997 and I.S. EN ISO 13789: 2000.

The following formulae may be used to derive elemental U-values (taking the unheated space into account) for typical housing situations irrespective of the precise dimensions of the unheated space.

$$U_o = 1 / (1/U - R_u) \quad \text{or} \quad U = 1 / (1/U_o + R_u)$$

Where: U – U-value of element adjacent to unheated space (W/m²K), taking the effect of the unheated space into account.

U_o – U-value of the element between heated and unheated spaces (W/m²K) calculated as if there was no unheated space adjacent to the element.

R_u – effective thermal resistance of unheated space inclusive of all external elements (m²K / W).

This procedure can be used when the precise details on the structure providing an unheated space are not available, or not crucial.

R_u for typical unheated structures (including garages, access corridors to flats and unheated conservatories) are given in [Tables A3, A4](#) and [A5](#).

[Table A5](#) applies only where a conservatory - style sunroom is not treated as an integral part of the dwelling i.e. is treated as an extension.

In the case of room-in-roof construction, the U-value of the walls of the room-in-roof construction and of the ceiling of the room below the space adjacent to these walls can be calculated using this procedure. See [Diagram A5](#).

Table A3 Typical resistance (R_u) for unheated space.

(a) Integral and adjacent single garages or other similar unheated space.

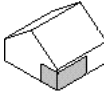
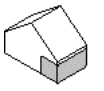
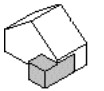
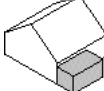
Garage or other similar unheated space	Element between garage and dwelling	R_u
Single fully integral 	Side wall, end wall and floor	0.33
Single fully integral 	One wall and floor	0.25
Single, partially integral displaced forward 	Side wall, end wall and floor	0.26
Single, adjacent 	One wall	0.09

The table gives R_u for single garages; use $(0.5 \times R_u)$ for double garages when extra garage is not fully integral, and $(0.85 \times R_u)$ for fully integral double garages. Single garage means a garage for one car; double garage means a garage for two cars.

Table A4 Typical resistance (R_u) for unheated space

(b) Unheated stairwells and access corridors in flats

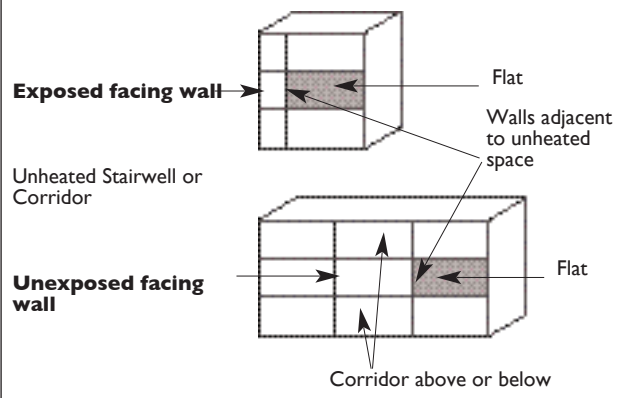

Unheated space	R_u
Stairwells:	
Facing wall exposed	0.82
Facing wall not exposed	0.90
Access corridors:	
Facing wall exposed, corridor above or below	0.31
Facing wall exposed, corridors above and below	0.28
Facing wall not exposed, corridor above and below	0.40
Facing wall not exposed, corridor above or below	0.43

Table A5 Typical resistance (R_u) for unheated space

(c) Conservatory-type sunroom

Number of walls between building and conservatory/sunroom	R_u
One	0.06
Two (conservatory in angle of building)	0.14
Three (conservatory in recess)	0.25

Diagram A5 Room in roof

Para. A.4.1

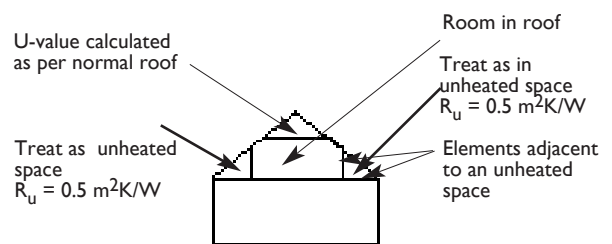

Appendix B: Fabric Insulation: Additional Guidance (including Tables of U-values) for Common Constructions

GENERAL

B.1 This Appendix provides some basic guidance in relation to typical roof, wall and floor constructions. Guidance is not exhaustive and designers and contractors should also have regard to other sources of relevant guidance e.g. BR.262, *Thermal Insulation; avoiding risks*, relevant standards and good building practice.

In particular, diagrams in this Appendix are intended to be illustrative of the construction to which they refer. They do not purport to provide detailed guidance on the avoidance of thermal bridging. See section 1.2.4 for guidance on reasonable provision in this regard.

B.2 For many typical roof, wall and floor constructions, the thickness of insulation required to achieve a particular U-value can be calculated approximately by the use of the appropriate table from this Appendix. The tables can also be used to estimate the U-value achieved by a particular thickness of insulating material. Higher performing insulating materials, i.e. those with lower thermal conductivities, can achieve any given U-value with a lower thickness of insulating material.

B.3 These tables have been derived using the methods described in [Appendix A](#), taking into account the effects of repeated thermal bridging where appropriate. Figures derived from the tables should be corrected to allow for any discrete non-repeating thermal bridging which may exist in the construction. A range of factors are relevant to the determination of U-values and the values given in these tables relate to typical constructions of the type to which the tables refer. The methods described in [Appendix A](#) can be used to calculate a more accurate U-value for a particular construction or the amount of insulation required to achieve a particular U-value.

B.4 Intermediate U-values and values of required thickness of insulation can be obtained from the tables by linear interpolation.

Example B1: Partially filled cavity

What is the U-value of the construction shown in [Diagram B1](#).

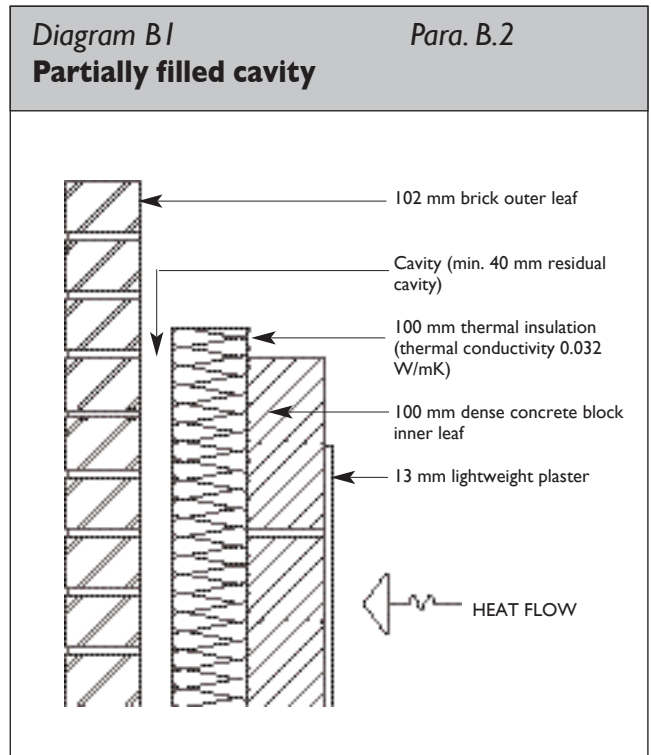

[Table B9](#) gives U-values of 0.29 W/m²K and 0.25 W/m²K for 100 mm insulation of thermal conductivity of 0.035 W/mK and 0.030 W/mK respectively. By linear interpolation, the U-value of this construction, with 100 mm of insulation of thermal conductivity of 0.032 W/mK, is 0.27 W/m²K.

Example B2: Timber frame wall

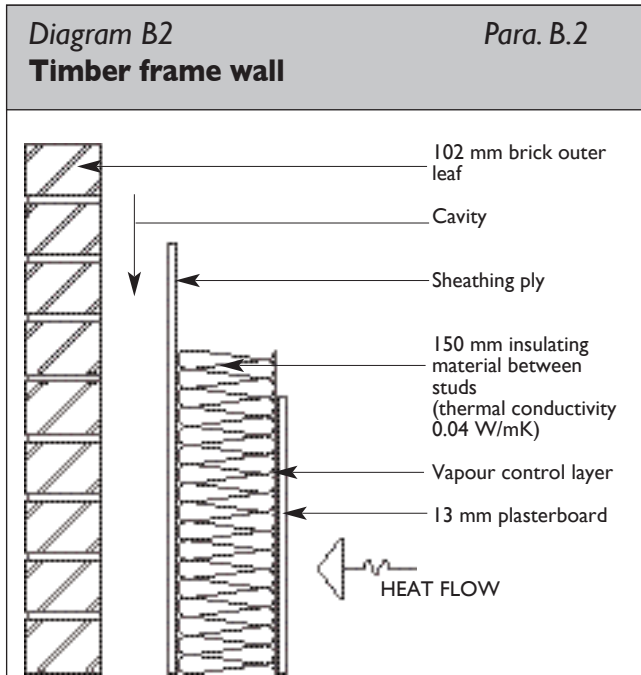

What is the U-value of this construction?
 Table B14 gives the U-value for 150 mm of insulation of thermal conductivity of 0.035 W/mK as 0.27 W/m²K.

Example B3: Pitched roof

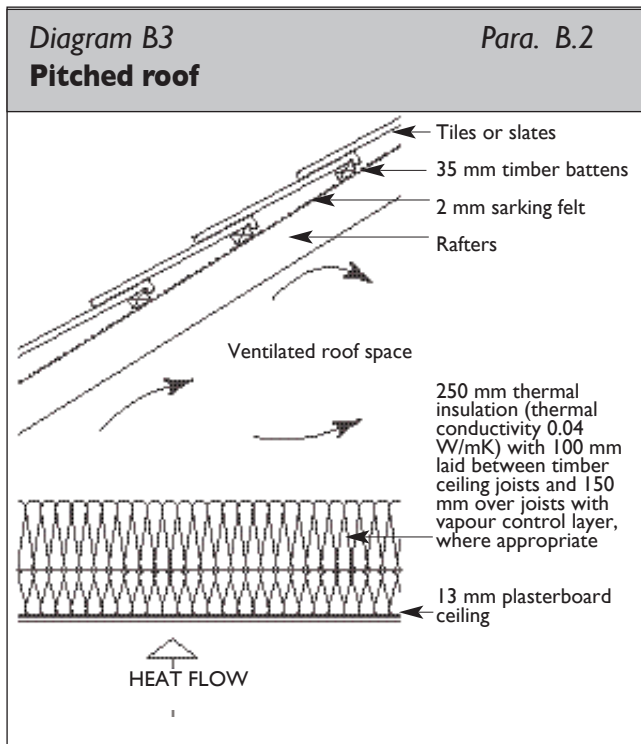

What is the U-value of this construction?
 Table B1 gives the U-value for 250 mm of insulation of thermal conductivity of 0.04 W/mK as 0.16 W/m² K.

ROOF CONSTRUCTIONS

B.5.1 Construction R1: Tiled or slated pitched roof, ventilated roof space, insulation at ceiling level.

B.5.1.1 R1(a) Insulation between and over joists

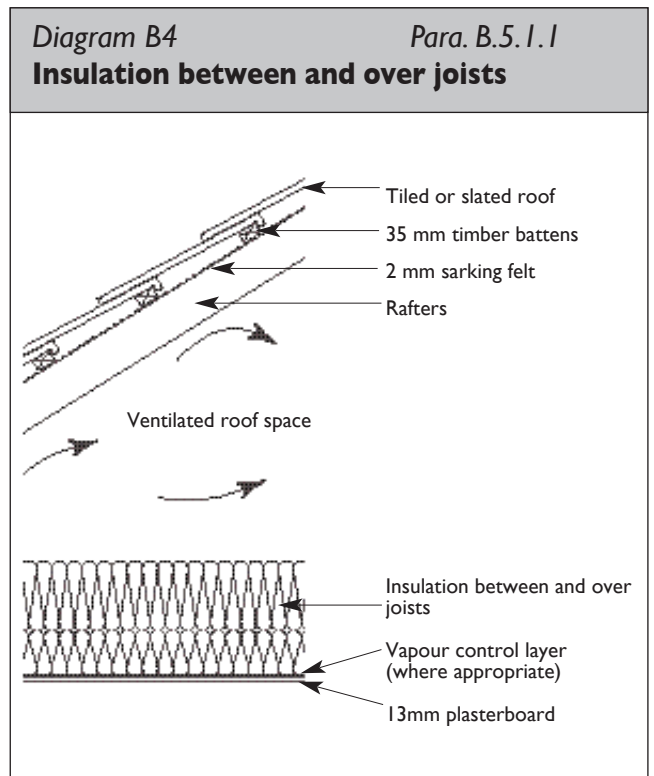

Table B1 U-values for tiled or slated pitched roof, ventilated roof space, insulation placed between and over joists at ceiling level

Total Thickness of insulation (mm)	Thermal conductivity of insulation (W/m K)				
	0.040	0.035	0.030	0.025	0.020
	U-Value of construction (W/m ² K)				
150	0.27	0.24	0.21	0.18	0.16
175	0.23	0.20	0.18	0.15	0.13
200	0.20	0.18	0.16	0.13	0.11
225	0.18	0.16	0.14	0.12	0.10
250	0.16	0.14	0.12	0.11	0.09
275	0.14	0.13	0.11	0.10	0.08
300	0.13	0.12	0.10	0.09	0.07

This table is derived for roofs with:

Tiles or slates, felt, ventilated roof space, timber joists ($\lambda = 0.13$) with the spaces between fully filled with insulation and the balance of insulation above and covering joists. (see [Diagram B4](#)). Calculations assume a fractional area of timber thermal bridging of 9%. (includes allowance for loft hatch framing)

Installation guidelines and precautions

Care is required in design and construction, particularly in regard to the following:

Provision of adequate roofspace ventilation

Adequate ventilation is particularly important to ensure the prevention of excessive condensation in cold attic areas. See relevant guidance in TGD F.

Minimising transfer of water vapour from occupied building area to cold attic space

In addition to ensuring adequate ventilation, measures should be taken to limit transfer of water vapour to the cold attic. Care should be taken to seal around all penetrations of pipes, ducts, wiring, etc. through the ceiling, including provision of an effective seal to the attic access hatch. Use of a vapour control layer at ceiling level, on the warm side of the insulation, will assist in limiting vapour transfer, but cannot be relied on as an alternative to ventilation. In particular, a vapour control layer should be used where the roof pitch is less than 15°, or where the shape of the roof is such that there is difficulty in ensuring adequate ventilation, e.g. room-in-the-roof construction.

Minimising the extent of cold bridging.

Particular areas of potential cold bridging include junctions with external walls at eaves and gables, and junctions with solid party walls. Gaps in the insulation should be avoided and the insulation should fit tightly against joists, noggings, bracing etc. Insulation joints should be closely butted and joints in upper and lower layers of insulation should be staggered.

Protecting water tanks and pipework against the risk of freezing.

All pipework on the cold side of the insulation should be adequately insulated. Where the cold water cistern is located in the attic, as is normally the case, the top and sides of the cistern should be insulated. The area underneath the cistern should be left uninsulated and continuity of tank and ceiling insulation should be ensured e.g. by overlapping the tank and ceiling insulation. Provision should be made to ensure ventilation of the tank.

Ensuring that there is no danger from overheating of electric cables or fittings.

Cables should be installed above the insulation. Cables which pass through or are enclosed in insulation should be adequately rated to ensure that they do not overheat. Recessed fittings should have adequate ventilation or other means to prevent overheating.

Providing for access to tanks, services and fittings in the roofspace.

Because the depth of insulation will obscure the location of ceiling joists, provision should be made for access from the access hatch to the cold water tank and to other fittings to which access for occasional maintenance and servicing may be required. This can be done by provision of walkways without compressing the installed insulation.

B.5.1.2 RI(b) Insulation between and below joists.

Insulation is laid in one layer between the joists, protruding above them where its depth is greater, and leaving air gaps above the joists. A composite board of plasterboard with insulation backing is used for the ceiling.

Diagram B5

Para. B.5.1.2

Insulation between and below joists

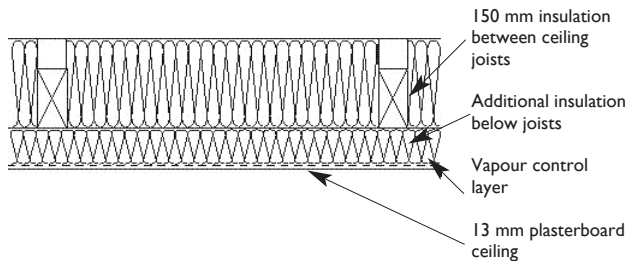

Installation guidelines and precautions.

Similar guidelines and precautions apply as for R1(a) above.

B.5.2 Construction R2: Tiled or slated pitched roof, occupied or unventilated roof space, insulation on roof slope.

B.5.2.1 R2(a) Insulation between and below rafters, 50 mm ventilated cavity between insulation and sarking felt.

Table B2 **U-values for tiled or slated pitched roof, ventilated roof space, insulation placed between and below joists at ceiling level**

Thickness of insulation below joists (mm)	Thermal conductivity of insulation (W/m K)				
	0.040	0.035	0.030	0.025	0.020
	U-Value of construction (W/m ² K)				
10	0.27	0.27	0.27	0.26	0.26
20	0.26	0.25	0.24	0.24	0.22
30	0.24	0.23	0.22	0.21	0.20
40	0.22	0.22	0.21	0.20	0.18
50	0.21	0.20	0.19	0.18	0.17
60	0.20	0.19	0.18	0.17	0.15
70	0.19	0.18	0.17	0.16	0.14
80	0.18	0.17	0.16	0.15	0.13
90	0.17	0.16	0.15	0.14	0.12
100	0.17	0.16	0.15	0.13	0.12
110	0.16	0.15	0.14	0.13	0.11
120	0.15	0.14	0.13	0.12	0.10

This table is derived for roofs as in [Table B1](#) but with 150 mm of insulation ($\lambda = 0.04$) between ceiling joists, and the remainder below the joists. Insulation of thickness and thermal conductivity as shown in the table is below joists. (See [Diagram B5](#)).

(The insulation thickness shown does not include the thickness of plasterboard in composite boards).

Diagram B6

Para. B.5.2.1

Insulation between and below rafters

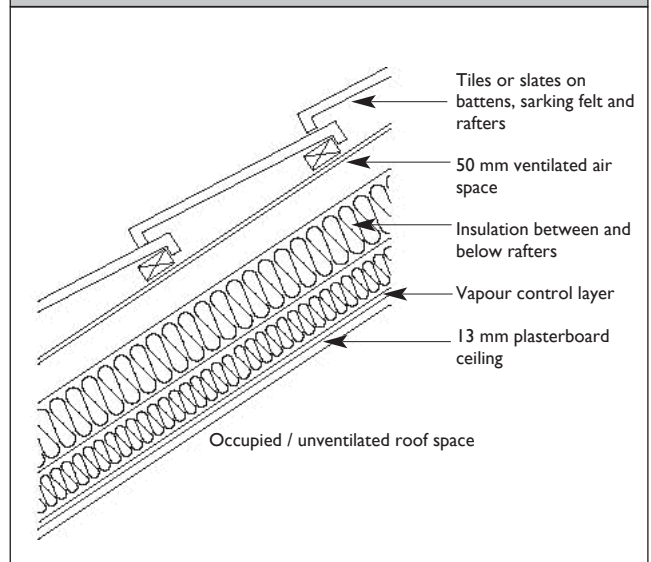

Table B3 U-values for tiled or slated pitched roof, occupied or unventilated roof space, insulation placed between and below rafters

Total thickness of insulation below joists (mm)	Thermal conductivity of insulation (W/m K)				
	0.040	0.035	0.030	0.025	0.020
	U-Value of construction (W/m ² K)				
120	0.34	0.31	0.27	0.24	0.20
140	0.29	0.26	0.23	0.20	0.16
160	0.25	0.23	0.20	0.17	0.14
180	0.22	0.20	0.17	0.15	0.12
200	0.20	0.18	0.16	0.13	0.11
220	0.18	0.16	0.14	0.12	0.10
240	0.17	0.15	0.13	0.11	0.09
260	0.15	0.14	0.12	0.10	0.08

This table is derived for roofs with:

Tiles or slates, felt, rafters of depth 150 mm ($\lambda = 0.13$), 50 mm ventilated air space above insulation, 100 mm insulation between rafters, balance of insulation below and across rafters. (See [Diagram B6](#)).

A fractional area of timber of 8% is assumed. Battens may be fixed to the underside of the rafters to increase rafter depth if necessary.

Installation guidelines and precautions.

The insulation is installed in two layers, one between the rafters (and battens) and the second below and across them. To limit water vapour transfer and minimise condensation risks, a vapour control layer is required on the warm side of the insulation. No material of high vapour resistance, e.g. facing layer attached to insulation to facilitate fixing, should be included within the overall thickness of insulation. Care must be taken to prevent roof timbers and access problems interfering with the continuity of insulation and vapour control layer.

Provision should be made for ventilation top and bottom of the 50 mm ventilation gap on the cold side of the insulation.

An alternative construction using a breathable membrane may be used. In this case the membrane should be certified in accordance with Part D of the Building Regulations and installed in accordance with the guidance on the certificate.

Care should be taken to avoid thermal bridging at roof-wall junctions at eaves, gable walls and party walls.

[Table B3](#) assumes that the thermal conductivity of insulation between and below the rafters is the same. If different insulation materials are used, the material on the warm side (i.e. below rafters) should have a vapour resistance no lower than that on the cold side (i.e. between rafters).

B.5.2.2 R2(b): Insulation above and between rafters, slate or tile underlay of breather membrane type.

Diagram B7

Para.5.2.2

Insulation above and between rafters

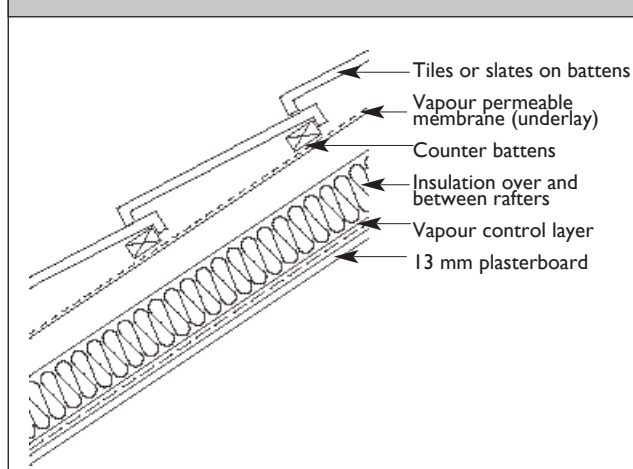

Table B4 U-values for tiled or slated pitched roof, occupied or unventilated roof space, insulation placed between and above rafters.

Total Thickness of insulation (mm)	Thermal conductivity of insulation (W/m K)				
	0.040	0.035	0.030	0.025	0.020
	U-Value of construction (W/m ² K)				
120	0.33	0.33	0.27	0.23	0.20
140	0.28	0.25	0.22	0.19	0.16
160	0.25	0.22	0.19	0.17	0.14
180	0.22	0.20	0.17	0.15	0.12
200	0.20	0.18	0.15	0.13	0.11
220	0.18	0.16	0.14	0.12	0.10
240	0.16	0.15	0.13	0.11	0.09
260	0.15	0.13	0.12	0.10	0.08

This table is derived for roofs with:

Tiles or slates, tiling battens, vapour permeable membrane (as underlay), counter battens, insulation layer over rafters, rafters with insulation fitted between. (See [Diagram B7](#)).

Insulation between and over rafters has the same thermal conductivity. A fractional area of timber of 8% is assumed.

Installation guidelines and precautions

The effective performance of this system is critically dependent on the prevention of air and water vapour movement between the warm and cold sides of the insulation. Only systems which are certified or shown by test and calculation as appropriate for this function, (see TGD D, Paragraph 1.1 (a) and (b)) should be used. The precise details of construction are dependent on the insulation and roof underlay materials to be used. Installation should be carried out precisely in accordance with the procedures described in the relevant certificate.

In general, the insulation material must be of low vapour permeability, there should be a tight fit between adjacent insulation boards, and between insulation boards and rafters. All gaps in the insulation (e.g. at eaves, ridge, gable ends, around rooflights and chimneys, etc.) should be sealed with flexible sealant or expanding foam.

Care should be taken to avoid thermal bridging at roof-wall junctions at eaves, gable walls and party walls.

B.5.3 Construction R3: Flat roof, timber joists, insulation below deck

B.5.3.1 R3(a) Insulation between joists, 50 mm air gap between insulation and roof decking

The insulation is laid between the joists. The depth of the joists is increased by means of battens if required.

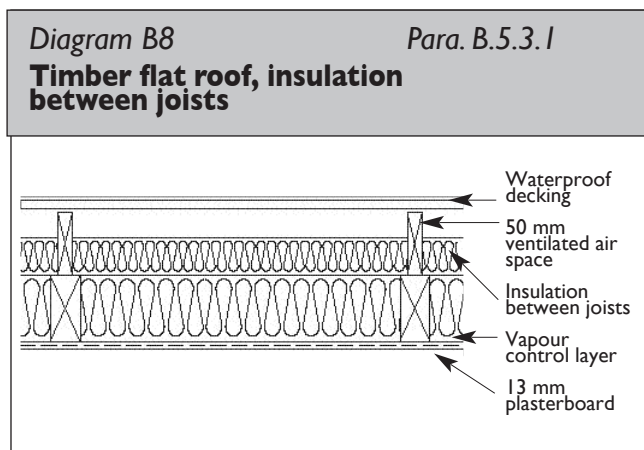

Table B5 U-values for timber flat roof, insulation between joists, 50 mm ventilated air gap between insulation and roof decking.

Total Thickness of insulation (mm)	Thermal conductivity of insulation (W/m K)				
	0.040	0.035	0.030	0.025	0.020
U-Value of construction (W/m ² K)					
150	0.29	0.26	0.24	0.21	0.18
175	0.25	0.23	0.20	0.18	0.16
200	0.22	0.20	0.18	0.16	0.14
225	0.20	0.18	0.16	0.14	0.12
250	0.18	0.16	0.15	0.13	0.11
275	0.16	0.15	0.13	0.12	0.10
300	0.15	0.14	0.12	0.11	0.09

This table is derived for roofs with:
 Weatherproof deck, ventilated air space, insulation as given above between timber joists ($\lambda = 0.13$), 13 mm plasterboard ($\lambda = 0.25$). (See [Diagram B8](#)).
 The calculations assume a fractional area of timber of 8%.

Installation guidelines and precautions

A vapour control layer sealed at all joints, edges and penetrations, is required on the warm side of the insulation, and a ventilated air space as specified in TGD F provided above the insulation. Cross ventilation should be provided to each and every void. When installing the insulation, care is needed to ensure that it does not block the ventilation flow paths.

The integrity of the vapour control layer should be ensured by effective sealing of all service penetrations, e.g. electric wiring, or by provision of a services zone immediately above the ceiling, but below the vapour control layer.

The roof insulation should connect with the wall insulation so as to avoid a cold bridge at this point.

B.5.3.2 R3(b) Insulation between and below joists, 50 mm air gap between insulation and roof decking

The insulation may be installed in two layers, one between the joists as described above, and the second below the joists. This lower layer may be in the form of composite boards of plasterboard backed with insulation, with integral vapour barrier, fixed to the joists. The edges of boards should be sealed with vapour-resistant tape.

Table B6: U-values for timber flat roof, insulation between and below joists, 50 mm ventilated air gap between insulation and roof decking.

Thickness of insulation below joists (mm)	Thermal conductivity of insulation (W/m K)				
	0.040	0.035	0.030	0.025	0.020
	U-Value of construction (W/m ² K)				
20	0.34	0.33	0.32	0.31	0.29
40	0.29	0.28	0.27	0.25	0.22
60	0.25	0.24	0.22	0.21	0.18
80	0.22	0.21	0.20	0.18	0.15
100	0.20	0.19	0.17	0.15	0.13
120	0.18	0.17	0.15	0.14	0.12
140	0.17	0.15	0.14	0.12	0.11
160	0.15	0.14	0.13	0.11	0.10

This table is derived for roofs as in [Table B5](#) above, except with 100 mm of insulation ($\lambda = 0.04$) between 150 mm joists, and composite board below joists consisting of 10 mm plasterboard ($\lambda = 0.25$) backed with insulation as specified in this table.

B.5.4 Construction R4: Sandwich warm deck flat roof

The insulation is installed above the roof deck but below the weatherproof membrane. The structural deck may be of timber, concrete or metal.

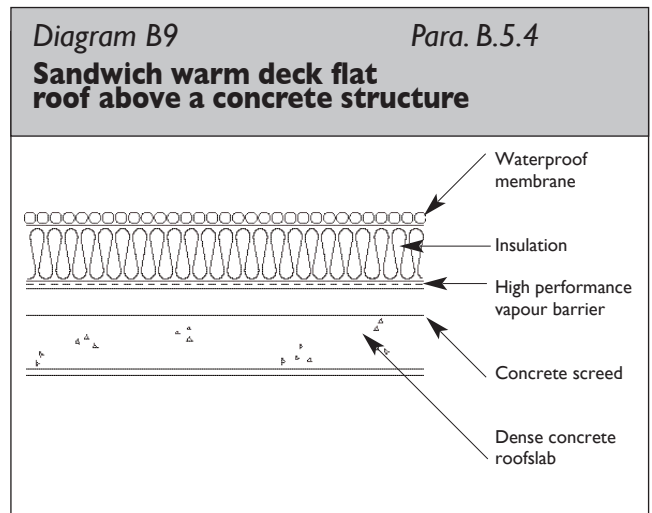

Table B7: U-values for sandwich warm deck flat roof.

Total thickness of insulation (mm)	Thermal conductivity of insulation (W/m K)				
	0.040	0.035	0.030	0.025	0.020
	U-Value of construction (W/m ² K)				
100	0.34	0.30	0.26	0.22	0.18
125	0.28	0.25	0.22	0.18	0.15
150	0.24	0.21	0.18	0.15	0.13
175	0.21	0.18	0.16	0.13	0.11
200	0.18	0.16	0.14	0.12	0.10
225	0.16	0.14	0.13	0.11	0.09
250	0.15	0.13	0.11	0.10	0.08

This table is derived for roofs with: 12 mm felt bitumen layers ($\lambda = 0.23$), over insulation as given in the table, over 50 mm screed ($\lambda = 0.41$), over 150 mm concrete slab ($\lambda = 2.30$), over 13 mm plasterboard ($\lambda = 0.25$). (See [Diagram B9](#)).

Installation guidelines and precautions

The insulation boards are laid over and normally fully bonded to a high performance vapour barrier complying with BS 747: 2000 which is bonded to the roof deck. The insulation is overlaid with a waterproof membrane, which may consist of a single layer membrane, a fully-bonded built-up bitumen roofing system, or mastic asphalt on an isolating layer. At the perimeter, the vapour barrier is turned up and back over the insulation and bonded to it and the weatherproof membrane. Extreme care is required to ensure that moisture can not penetrate the vapour barrier.

The insulation should not be allowed to get wet during installation.

There should be no insulation below the deck. This could give rise to a risk of condensation on the underside of the vapour barrier.

Thermal bridging at a roof / wall junction should be avoided.

B.5.5 Construction R5: Inverted warm deck flat roof: insulation to falls above both roof deck and weatherproof membrane

Insulation materials should have low water absorption, be frost resistant and should maintain performance in damp conditions over the long term. To balance loss of performance due to the damp conditions and the intermittent cooling effect of water passing through and draining off from the warm side of the insulation, the insulation thickness calculated as necessary for dry conditions should be increased by 20%.

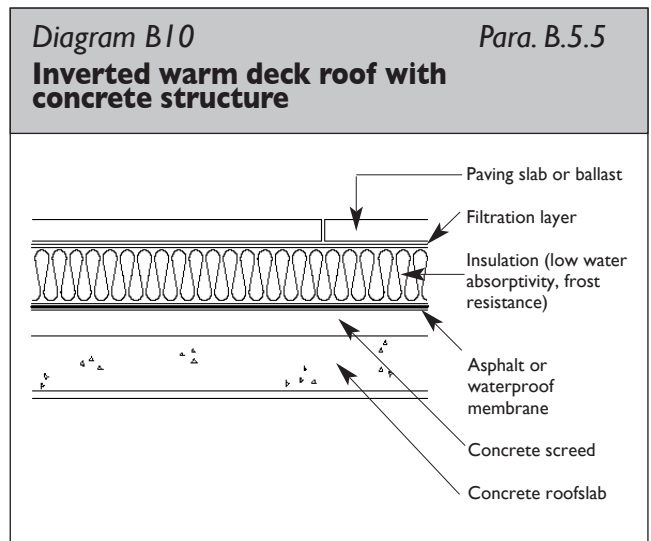

Table B8: U-values for sandwich warm deck flat roof.

Total thickness of insulation (mm)	Thermal conductivity of insulation (W/m K)				
	0.040	0.035	0.030	0.025	0.020
	U-Value of construction (W/m ² K)				
100	0.42	0.39	0.35	0.32	0.28
125	0.37	0.34	0.31	0.28	0.25
150	0.33	0.30	0.28	0.25	0.23
175	0.30	0.28	0.26	0.23	0.21
200	0.28	0.26	0.24	0.22	0.20
225	0.26	0.24	0.23	0.21	0.19
250	0.25	0.23	0.21	0.20	0.18
275	0.24	0.22	0.21	0.19	0.18
300	0.23	0.21	0.20	0.18	0.17

This table is derived for roofs with: 50 mm gravel ballast ($\lambda= 2.0$) over 40 mm screed ($\lambda= 0.50$) over 40 mm screed ($\lambda= 0.41$) over 150 mm concrete ($\lambda= 2.30$) over 13 mm plasterboard ($\lambda = 0.25$). Insulation thickness derived using correction factor for rain water flow given in I.S. EN 6946. (See [Diagram B10](#)).

Installation guidelines and precautions

The insulation is laid on the waterproof membrane. A filtration layer is used to keep out grit, which could eventually damage the weatherproof membrane. The insulation must be restrained to prevent wind uplift and protected against ultraviolet degradation. This is usually achieved by use of gravel ballast, paving stones or equivalent restraint and protection. The insulation should have sufficient compressive strength to withstand the weight of the ballast and any other loads.

Rainwater will penetrate the insulation as far as the waterproof membrane. Drainage should be provided to remove this rainwater. To minimise the effect of rain on performance, insulation boards should be tightly jointed (rebated or tongued-and-grooved edges are preferred), and trimmed to give a close fit around upstands and service penetrations.

To avoid condensation problems, the thermal resistance of the construction between the weatherproof membrane and the heated space is at least 0.15 m²K/W. However, this thermal resistance should not exceed 25% of the thermal resistance of the whole construction.

Thermal bridging at roof / wall junctions should be avoided.

WALL CONSTRUCTIONS

B.6.1. WI: Cavity walls, insulation in cavity, cavity retained (partial fill)

B.6.1.1 WI(a) Brick or rendered dense concrete block external leaf, partial fill insulation, dense concrete block inner leaf, plaster or plasterboard internal finish.

Diagram B11

Para. B.6.1.1

Cavity wall with partial-fill insulation

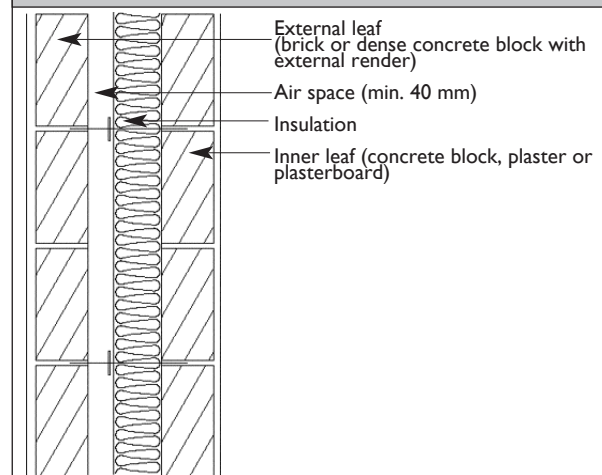

The following tables deal with walls with maximum overall cavity width of 150 mm, which is the greatest cavity width for which details of construction are given in I.S. 325 Part 1: 1986, *Code of Practice for the structural use of concrete; Structural use of unreinforced concrete*. Where it is proposed to use wider cavity widths, full structural and thermal design will be necessary.

Table B9: **U-values for brick (or rendered dense concrete block) external leaf, partial fill insulation, dense concrete block inner leaf, plaster (or plasterboard) internal finish.**

Total thickness of insulation (mm)	Thermal conductivity of insulation (W/m ² K)				
	0.040	0.035	0.030	0.025	0.020
U-Value of construction (W/m ² K)					
60	0.48	0.43	0.39	0.33	0.28
80	0.39	0.35	0.31	0.26	0.22
100	0.32	0.29	0.25	0.22	0.18

This table is derived for walls with:

102 mm clay brickwork outer leaf ($\lambda = 0.77$), 50 mm air space, insulation as specified in table, 100 mm concrete block inner leaf (density = 1800 kg/m³, $\lambda = 1.13$), 13 mm dense plaster ($\lambda = 0.57$). (See [Diagram B11](#)). The effects of wall ties are assumed to be negligible.

The insulation thickness required to achieve a given U-value may be reduced by using lightweight concrete insulating blocks for the inner leaf, as shown in the table below.

Table B10: U-values for construction as Table B9 except for lightweight concrete block inner leaf.

Total thickness of insulation (mm)	Thermal conductivity of insulation (W/m ² K)				
	0.040	0.035	0.030	0.025	0.020
	U-Value of construction (W/m ² K)				
60	0.40	0.37	0.34	0.30	0.25
80	0.34	0.31	0.27	0.24	0.20
100	0.29	0.26	0.23	0.20	0.17

This table is derived for walls as in Table B9, except heavyweight concrete block inner leaf replaced with 100 mm insulating block ($\lambda = 0.18$). Calculations assume a 7% fractional area of mortar ($\lambda = 0.88$) bridging the inner leaf.

Note that the sound attenuation performance of lightweight blocks is not as good as that of heavier blocks. This may limit their suitability for use in the inner leaves of attached buildings.

Installation guidelines and precautions

Insulation should be tight against the inner leaf. Any excess mortar should be cleaned off before fixing insulation. The insulation layer should be continuous and without gaps. Insulation batts should butt tightly against each other. Mortar droppings on batts should be avoided. Batt should be cut and trimmed to fit tightly around openings, cavity trays, lintels, sleeved vents and other components bridging the cavity, and should be adequately supported in position.

Critical locations where care should be taken to limit thermal bridging include lintels, jambs, cills, roof-wall junctions and wall-floor junctions. The method of cavity closure used should not cause thermal bridge at the roof-wall junction.

B.6.1.2 WI(b): As WI(a) except with insulation partly in cavity and partly as internal lining.

If composite boards of plasterboard backed with insulation (of similar conductivity to that used in the cavity) are used internally. Table B9 and B10 can be taken as applying to the total insulation thickness (cavity plus internal). If internal insulation is placed between timber studs, total insulation thickness will be slightly higher due to the bridging effect of the studs. Table B11 applies in this case.

Table B11: U-values for brick (or rendered dense concrete block) external leaf, 60mm partial fill insulation ($\lambda = 0.035$), dense concrete block inner leaf, plasterboard fixed to timber studs, insulation between studs.

Total thickness of insulation between studs (mm)	Thermal conductivity of insulation (W/m K)				
	0.040	0.035	0.030	0.025	0.020
	U-Value of construction (W/m ² K)				
40	0.31	0.31	0.29	0.28	0.26
60	0.28	0.27	0.26	0.24	0.22
80	0.25	0.24	0.23	0.21	0.19
100	0.23	0.22	0.20	0.19	0.17
120	0.21	0.20	0.18	0.17	0.15

This table is derived for walls as in Table B9 above, except with 60 mm of insulation of $\lambda = 0.035$ in cavity, and insulation as specified in the table applied to the internal surface of the wall between timber studs ($\lambda = 0.13$) of fractional area 12%, with a wall finish of 13 mm plasterboard ($\lambda = 0.25$).

Lower U-values, or reduced insulation thickness, can be achieved by using insulating concrete blockwork (rather than dense concrete) between the cavity and internal insulation.

Insulation partly in cavity and partly as internal lining helps minimise thermal bridging. Internal insulation limits thermal bridging at floor and roof junctions, whereas cavity insulation minimises thermal bridging at separating walls and internal fixtures.

Installation guidelines and precautions

Installation of insulation in the cavity should follow the guidelines given above for construction WI(a) (partial-fill cavity insulation), and installation of the

internal lining should follow the guidelines given below for construction W4 (hollow-block).

B.6.2. Construction W2: Cavity walls, insulation in cavity, no residual cavity (full-fill)

The insulation fully fills the cavity. Insulation may be in the form of semi-rigid batts installed as wall construction proceeds, or loose-fill material blown into the cavity after the wall is constructed; the former is considered here. Insulation material suitable for cavity fill should not absorb water by capillary action and should not transmit water from outer to inner leaf. Such insulation may extend below dpc level.

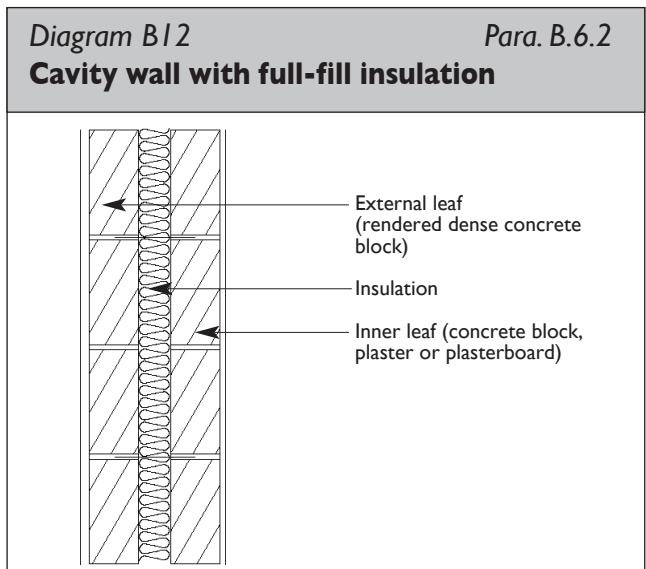

Table B12: U-values for rendered dense concrete block external leaf, full-fill insulation dense concrete block inner leaf, plaster (or plasterboard) internal finish.

Total thickness of insulation (mm)	Thermal conductivity of insulation (W/mK)				
	0.040	0.035	0.030	0.025	0.020
	U-Value of construction (W/m ² K)				
60	0.51	0.46	0.41	0.35	0.29
80	0.41	0.37	0.32	0.27	0.22
100	0.34	0.30	0.26	0.22	0.18
120	0.29	0.26	0.22	0.19	0.16
140	0.25	0.22	0.20	0.17	0.13
160	0.22	0.20	0.17	0.15	0.12

This table is derived for walls with: 20 mm external rendering ($\lambda = 0.57$), 102 mm clay brickwork outer leaf ($\lambda = 0.77$), insulation as specified in table, 100 mm concrete block inner leaf (medium density - 1800 kg/m³, $\lambda = 1.13$), 13 mm dense plaster ($\lambda = 0.57$). The effects of wall ties are assumed to be negligible. (See Diagram B12).

The insulation thickness required to achieve a given U-value may be reduced by using insulating concrete blocks for the inner leaf, as shown in the table below.

Table B13: U-values for rendered dense concrete block external leaf, full-fill insulation, lightweight concrete block inner leaf, plaster (or plasterboard) internal finish.

Total thickness of insulation (mm)	Thermal conductivity of insulation (W/mK)				
	0.040	0.035	0.030	0.025	0.020
	U-Value of construction (W/m ² K)				
60	0.43	0.39	0.35	0.31	0.26
80	0.35	0.32	0.29	0.25	0.21
100	0.30	0.27	0.24	0.21	0.17
120	0.26	0.23	0.21	0.18	0.15
140	0.23	0.21	0.18	0.16	0.13
160	0.21	0.18	0.16	0.14	0.11

This table is derived for walls as above, except heavyweight concrete block inner leaf replaced with 100 mm insulating block ($\lambda = 0.18$). Calculations assume a 7% fractional area of mortar ($\lambda = 0.88$) bridging the inner leaf.

Installation guidelines and precautions

Only certified insulation products should be used, and the installation and other requirements specified in such certificates should be fully complied with. In particular, regard should be had to the exposure conditions under which use is certified and any limitations on external finish associated therewith.

Guidance on minimising air gaps and infiltration in partial-fill cavity insulation applies also to full-fill insulation.

Similar issues regarding avoidance of thermal bridging as for construction apply.

B.6.3 Construction W3: Timber frame wall, brick or rendered concrete block external leaf

B.6.3.1 W3(a) Insulation between studs

The insulation is installed between studs, whose depth equals or exceeds the thickness of insulation specified.

In calculating U-values, the fractional area of timber bridging the insulation should be checked. Account should be taken of all timber elements which fully bridge the insulation, including studs, top and bottom rails, noggings, timbers around window and door openings and at junctions with internal partitions, party walls and internal floors. In the table a fractional area of 15% is assumed.

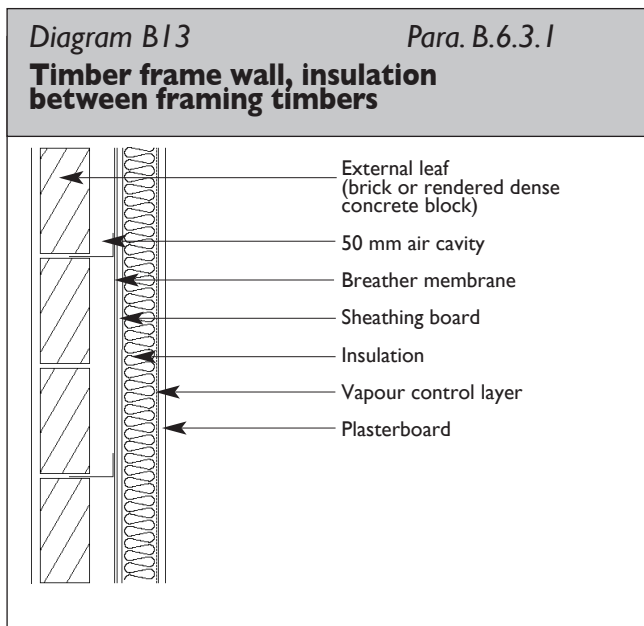

Table B14: U-values for brick (or rendered dense concrete block) external leaf, timber frame inner leaf, insulation between timber studs, plasterboard internal finish.

Total thickness of insulation (mm)	Thermal conductivity of insulation (W/mK)				
	0.040	0.035	0.030	0.025	0.020
U-Value of construction (W/m ² K)					
100	0.39	0.36	0.34	0.31	0.28
125	0.33	0.31	0.28	0.28	0.23
150	0.29	0.27	0.24	0.24	0.20
175	0.25	0.23	0.21	0.21	0.18

This table is derived for walls with: 102 mm clay brickwork outer leaf ($\lambda = 0.77$), 50 mm air cavity, breather membrane, 12 mm sheathing board ($\lambda = 0.14$), insulation between timber studs ($\lambda = 0.13$), vapour control layer, 13 mm plasterboard ($\lambda = 0.25$). (See [Diagram B13](#)). The calculations assume a fractional area of timber thermal bridging of 15%.

Installation guidelines and precautions

Air gaps in the insulation layer, and between it and the vapour barrier, should be avoided. Insulation batts should be friction fitted between studs to minimise gaps between insulation and joists. Adjacent insulation pieces should butt tightly together. Particular care is needed to fill gaps between closely-spaced studs at wall/wall and wall/floor junctions, and at corners of external walls.

A vapour control layer should be installed on the warm side of the installation. There should be no layers of high vapour resistance on the cold side of the insulation.

Care is required to minimise thermal bridging of the insulation by timber noggings and other inserts.

B.6.3.2 W3(b): Insulation between and across studs

Where the chosen stud depth is not sufficient to accommodate the required thickness of insulation, insulation can be installed to the full depth between the studs with additional insulation being provided as an internal lining. This additional insulation may be either in the form of plasterboard/insulation composite board or insulation between timber battens, to which the plasterboard is fixed.

Table B15: U-values for brick (or rendered dense concrete block) external leaf, timber frame inner leaf, insulation between 100 mm timber studs, additional insulation, plasterboard internal finish.

Total thickness of insulation across studs (mm)	Thermal conductivity of insulation (W/m K)				
	0.040	0.035	0.030	0.025	0.020
	U-Value of construction (W/m ² K)				
20	0.32	0.32	0.31	0.29	0.28
40	0.28	0.27	0.25	0.24	0.22
60	0.24	0.23	0.22	0.20	0.18
80	0.22	0.20	0.19	0.17	0.15
100	0.19	0.18	0.17	0.15	0.13

This table is derived for walls as in W3(a) above, except with 100 mm of insulation of $\lambda = 0.04$ between 100 mm studs, and an additional layer of insulation as specified in the table across the studs.

The vapour control layer should be on the warm side of the insulation. If different types of insulation are used between and inside the studs, the vapour resistance of the material between the studs should not exceed that of the material across them.

B.6.4 Construction W4: Hollow concrete block wall, rendered externally, internal insulation lining with plasterboard finish.

Diagram B14

Para. B.6.4

Hollow-block wall, internal insulation lining

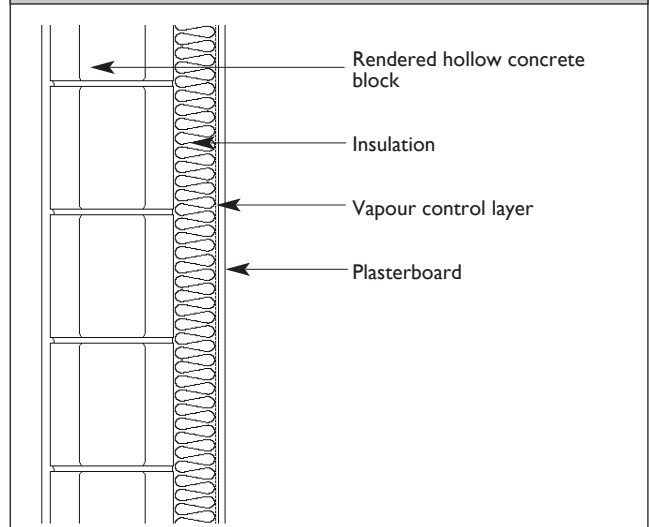

The insulation is installed on the inner face of the masonry walls. It may be installed between preservative-treated timber studs fixed to the wall, or in the form of composite boards of plaster backed with insulation, or as a combination of these.

Installation guidelines and precautions

Air Movement

Air gaps in the insulation layer should be kept to a minimum. If using insulation between timber studs, there should be no gaps between insulation and studs, between insulation and the vapour control layer, between butt joints in the insulation, around service penetrations, etc. If using composite boards, they should be tightly butted at edges, and should provide complete and continuous coverage of the external wall.

When mounting composite boards on plaster dabs or timber battens, there is a danger that air will be able to circulate behind the insulation, reducing its effectiveness. To minimise such air movement, the air gap behind the boards should be sealed along top and bottom, at corners and around window and door openings e.g. with continuous ribbon of plaster or timber studs.

Table B16: U-values for hollow-block wall, rendered externally, plasterboard fixed to timber studs internally, insulation between studs.

Total thickness of insulation (mm)	Thermal conductivity of insulation (W/mK)				
	0.040	0.035	0.030	0.025	0.020
	U-Value of construction (W/m ² K)				
50	0.67	0.63	0.58	0.53	0.47
75	0.50	0.47	0.43	0.39	0.34
100	0.40	0.37	0.34	0.31	0.27
125	0.34	0.31	0.28	0.25	0.23
150	0.29	0.26	0.24	0.22	0.19
175	0.25	0.23	0.21	0.19	0.17
200	0.22	0.21	0.19	0.17	0.15

Table B17: U-values of hollow-block wall, rendered externally, composite insulation/ plasterboard internally, fixed to timber battens [or plaster dabs]

Total thickness of insulation (mm)	Thermal conductivity of insulation (W/mK)				
	0.040	0.035	0.030	0.025	0.020
	U-Value of construction (W/m ² K)				
40	0.63	0.58	0.52	0.46	0.39
50	0.55	0.50	0.45	0.39	0.32
60	0.48	0.44	0.39	0.34	0.28
70	0.43	0.39	0.34	0.30	0.25
80	0.39	0.35	0.31	0.26	0.22
90	0.35	0.32	0.28	0.24	0.20
100	0.32	0.29	0.26	0.22	0.18
110	0.30	0.27	0.24	0.20	0.16
120	0.28	0.25	0.22	0.19	0.15
130	0.26	0.23	0.20	0.17	0.14
140	0.25	0.22	0.19	0.16	0.13
150	0.23	0.21	0.18	0.15	0.12

These tables are derived for walls with: 19 mm external rendering ($\lambda = 1.00$), 215 mm hollow concrete block (thermal resistance = 0.21 m²K/W), insulation fixed as stated, vapour control layer, 13 mm plasterboard ($\lambda = 0.25$). (See [Diagram B14](#)).

The calculations assume a fractional area of timber thermal bridging of 12% or plaster dab thermal bridging of 20%. as appropriate of 8%.

Condensation

A vapour control layer (e.g. 500 gauge polythene) should be installed on the warm side of the insulation to minimise the risk of interstitial

condensation on the cold masonry behind the insulation. Care should be taken to avoid gaps in the vapour control layer at all joints, edges and service penetrations. The location of service runs in the air gap on the cold side of the insulation should be avoided.

Thermal Bridging

Care should be taken to minimise the impact of thermal bridging. Critical locations have been identified for construction WI. These also apply to this construction.

Other areas where there is a risk of significant thermal bridging include:

Junctions with solid party walls and partitions

Internal partition or party walls of solid dense concrete blockwork can create significant thermal bridge effects at junctions with single leaf masonry external walls.

Junctions with intermediate floors

The external walls in the floor space of intermediate floors should be insulated and protected against vapour movement. Along the wall running parallel to the joists, insulation can be placed between the last joist and the wall. Where the joists are perpendicular to the wall, the insulation and vapour control layer should be continuous through the intermediate floor space and should be carefully cut to fit around the joist ends.

Stairs, cupboards and other fittings supported on or abutting the external wall

Insulation should be carried through behind such fittings.

Ducts, e.g. Soil and vent pipe ducts, against external walls

Insulation should be continuous at all such ducts, i.e. the insulation should be carried through on either the external or internal side of such ducts. Where the insulation is on the external side, particular care should be taken to prevent ingress of cold external air where ducts etc. penetrate the insulation.

FLOOR CONSTRUCTIONS

B.7.1 Construction F1: Ground floor: concrete slab-on-ground. Insulation under slab or under screed

For continuous and uniform insulation under the full ground floor area, the insulation thickness required to achieve prescribed U-values for slab-on-ground floors are given below. These tables apply whether the insulation is located under the slab or under the screed.

Table B18 allows estimation of the U-value of an insulated floor from the ratio of the length of exposed perimeter to floor area and the thermal resistance of the applied insulation. Table B19 gives the thickness of insulation required to achieve a given U-value when the ratio of exposed perimeter to floor area and the thermal conductivity of the material is known. Both tables are derived for uniform full-floor insulation, ground conductivity of $2.0 \text{ W/m}^2\text{K}$ and full thickness of walls taken to be 0.3 m .

Diagram B15

Para. B.7.1

Concrete slab-on-ground floor, insulation under slab

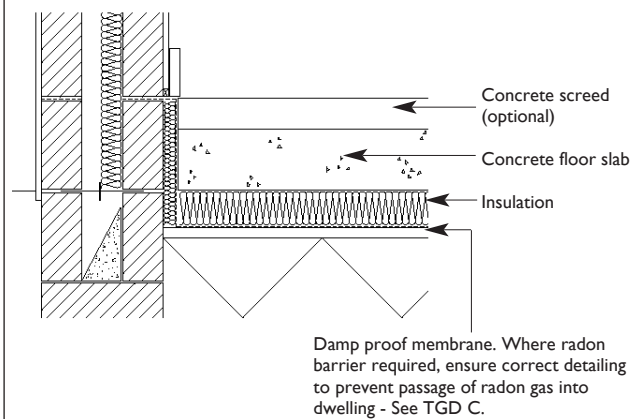

Installation guidelines and precautions

The insulation may be placed above or below the dpm/radon barrier. The insulation should not absorb moisture and, where placed below the dpm/radon barrier, should perform well under prolonged damp conditions and should not be degraded by any waterborne contaminants in the soil or fill.

The insulation should have sufficient load-bearing capacity to support the floor and its loading.

The insulation is laid horizontally over the whole area of the floor. Insulation boards should be tightly butted, and cut to fit tightly at edges and around service penetrations.

Diagram B16

Para. B.7.1

Concrete slab-on-ground floor, insulation under screed

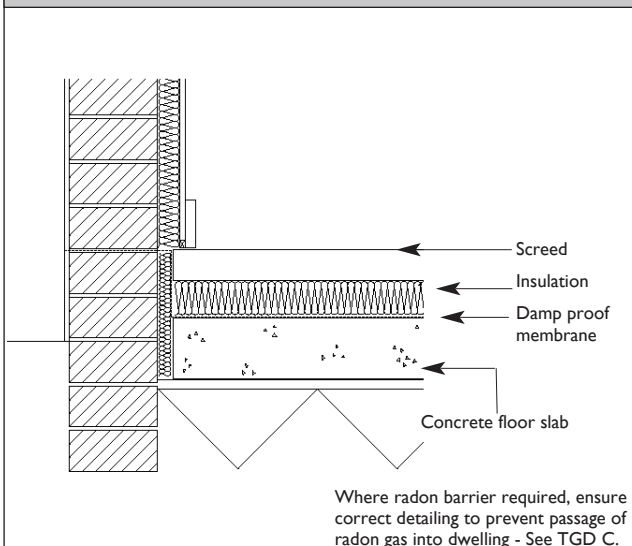

Table B18: U-value of insulated ground floor as a function of floor area, exposed perimeter and thermal resistance of added insulation (U_{ins}).

Exposed Perimeter/Area (P/A) (m-1)	Thermal Resistance of Added Insulation [R_{ins}] (m^2K/W)											
	0.75	1.0	1.25	1.5	1.75	2.0	2.25	2.5	2.75	3.0	3.5	4.0
1.00	0.66	0.57	0.50	0.44	0.40	0.36	0.33	0.31	0.28	0.27	0.23	0.21
0.90	0.64	0.55	0.48	0.43	0.39	0.36	0.33	0.30	0.28	0.26	0.23	0.21
0.80	0.62	0.54	0.47	0.42	0.38	0.35	0.32	0.30	0.28	0.26	0.23	0.21
0.70	0.59	0.52	0.46	0.41	0.37	0.34	0.31	0.29	0.27	0.25	0.23	0.20
0.60	0.57	0.50	0.44	0.40	0.36	0.33	0.31	0.28	0.27	0.25	0.22	0.20
0.50	0.53	0.47	0.42	0.38	0.35	0.32	0.30	0.27	0.26	0.24	0.22	0.19
0.40	0.48	0.43	0.39	0.36	0.33	0.30	0.28	0.26	0.25	0.23	0.21	0.19
0.30	0.43	0.39	0.35	0.32	0.30	0.28	0.26	0.24	0.23	0.22	0.20	0.18
0.20	0.35	0.32	0.30	0.28	0.26	0.24	0.23	0.22	0.21	0.20	0.18	0.16

Table B19: Concrete slab-on-ground floors: Insulation thickness required for U-value of 0.25 W/m²K.

Exposed Perimeter/Area P/A (m-1)	Thermal conductivity of insulation (W/mK)				
	0.040	0.035	0.030	0.025	0.020
	Total thickness of insulation (mm)				
0.1	10	8	7	6	5
0.2	64	56	48	40	32
0.3	88	77	66	55	44
0.4	100	88	75	63	50
0.5	110	96	82	69	55
0.6	116	101	87	72	56
0.7	120	105	90	75	60
0.8	123	108	93	77	62
0.9	126	110	94	79	63
1.0	128	112	96	80	64

protected during power-floating, e.g. by boards, or the areas close to the edge of the floor should be hand trowelled.

Thermal bridging at floor-wall junctions should be minimised.

With cavity walls, thermal bridging via the inner leaf is difficult to avoid, but adequate provision to limit it should be made.

Care should be taken to prevent damage or dislodgement of insulation during floor laying. If the dpm is placed below the insulation, the joints between insulation boards should be taped to prevent wet screed from entering when being poured. If the slab/screed is power-floated, the exposed edges of perimeter insulation should be

B.7.2 Construction F2: Ground floor: suspended timber floor, insulation between joists.

Diagram B17 *Para. B.7.2*

Suspended timber floor with quilt insulation

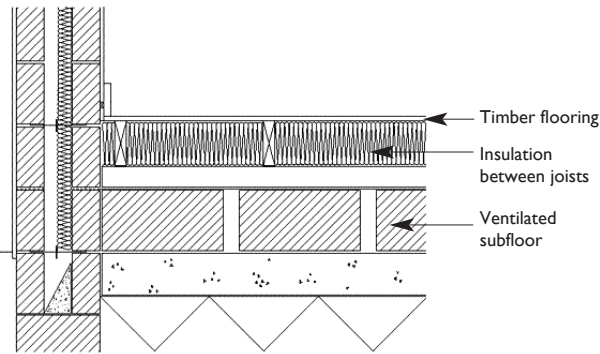

Timber flooring
 Insulation between joists
 Ventilated subfloor

Note: Where radon barrier required, ensure correct detailing to prevent passage of radon gas into the building - See TGD C.

Diagram B18 *Para. B.7.2*

Suspended timber floor with rigid or semi-rigid board insulation

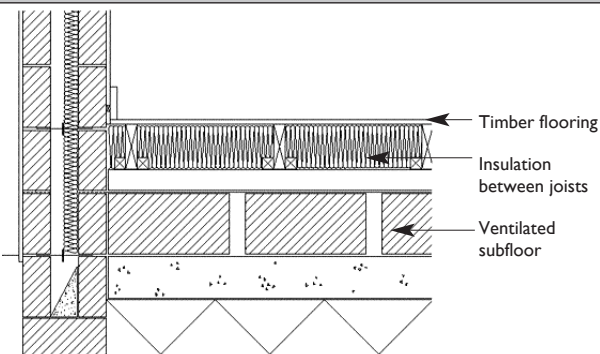

Timber flooring
 Insulation between joists
 Ventilated subfloor

Note: Where radon barrier required, ensure correct detailing to prevent passage of radon gas into the building - See TGD C.

Table B20: Suspended timber ground floors: Insulation thickness required for U-value of 0.25 W/m²K.

Exposed Perimeter Area P/A (m-1)	Thermal conductivity of insulation (W/mK)				
	0.040	0.035	0.030	0.025	0.020
Total thickness of insulation (mm)					
0.1	39	35	31	27	23
0.2	96	87	77	68	58
0.3	117	106	94	83	71
0.4	128	116	103	91	78
0.5	135	122	109	96	82
0.6	139	126	113	99	86
0.7	143	129	116	102	88
0.8	146	132	118	104	89
0.9	148	134	120	105	91
1.0	150	135	121	107	92

This table is derived for:
 Suspended floor consisting of 20 mm timber flooring ($\lambda = 0.13$) on timber joists ($\lambda = 0.13$), with insulation between the joists. Ventilated sub-floor space underneath. (See [Diagrams B17 and B18](#)).
 A fractional area of timber thermal bridging of 11% is assumed.

Installation guidelines and precautions

Where mineral wool quilt insulation is used, the insulation is supported on polypropylene netting or a breather membrane draped over the joists and held against their sides with staples or battens. The full thickness of insulation should extend for the full width between joists. Insulation should not be draped over joists, but cut to fit tightly between them.

Alternatively, rigid or semi-rigid insulation boards, supported on battens nailed to the sides of the joists, may be used.

Thermal bridging, and air circulation around the insulation from the cold vented air space below, should be minimised. The insulation should fit tightly against the joists and the flooring above. Careful placement of supporting battens (or staples) is required to achieve this. At floor-wall junctions the insulation should extend to the walls. The space between the last joist and the wall should be packed with mineral wool to the full depth of the joist. Where internal wall insulation is used, the floor and

wall insulation should meet. Where cavity insulation is used, the floor insulation should be turned down on the internal face and overlap the cavity insulation, or insulating blocks used in the wall at this level.

Cross-ventilation should be provided to the sub-floor space to remove moisture.

Water pipes in the sub-floor space should be insulated to prevent freezing.

B.7.3 Construction F3: Ground floor: suspended concrete floor

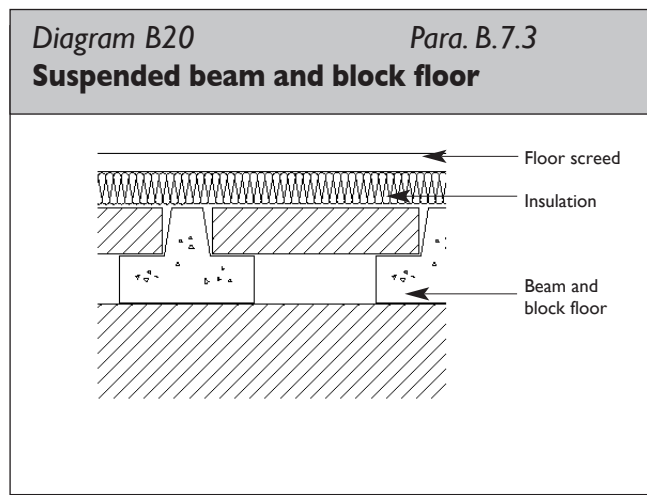
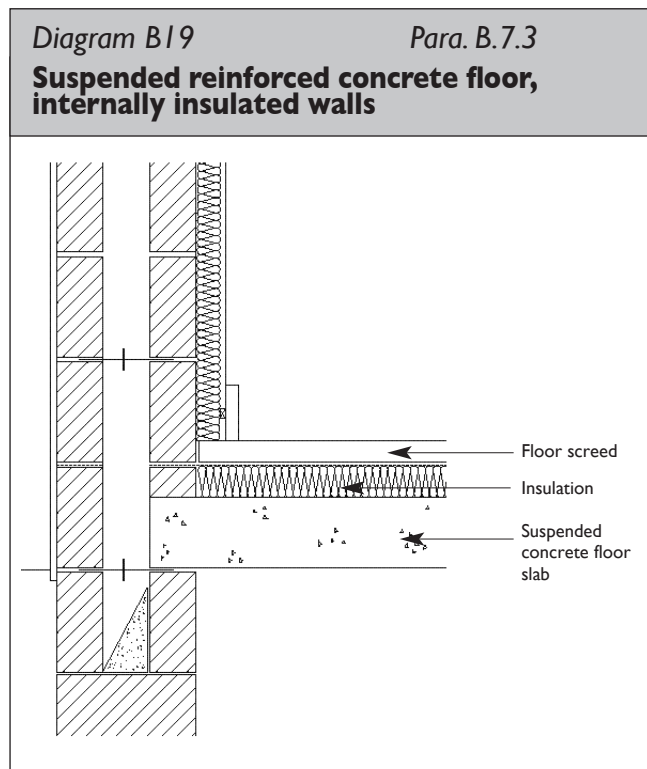

Table B21: Suspended concrete ground floors: Insulation thickness required for U-value of 0.25 W/m²K.

Exposed Perimeter/ Area (P/A) (m-1)	Thermal conductivity of insulation (W/mK)				
	0.040	0.035	0.030	0.025	0.020
	Total thickness of insulation (mm)				
0.1	19	17	14	12	10
0.2	69	60	52	43	35
0.3	87	76	65	54	44
0.4	96	84	72	60	48
0.5	102	89	77	64	51
0.6	106	93	80	67	53
0.7	109	96	82	69	55
0.8	112	98	84	70	56
0.9	114	99	85	71	57
1.0	115	101	86	72	58

This table is derived for floors with:
 65 mm screed ($\lambda = 0.41$) on insulation on 150 mm cast concrete ($\lambda = 2.20$). Full thickness of walls = 0.3 m, U-value of sub-floor walls: 2 W/m²K. Height of floor surface above ground level: 0.3 m. (See [Diagrams B19 and B20](#)).
 Unventilated sub-floor crawl space underneath.

Installation guidance and precautions

If the walls are internally insulated, it is recommended that the floor insulation be placed above the floor structure, since it can then connect with the wall insulation. Thermal bridging at the floor-wall junction is difficult to avoid when insulation is placed below the floor structure.

If the walls are cavity insulated, floor insulation can not connect with wall insulation, so some thermal bridging is inevitable. It can be minimised by using insulating blocks for the inner leaf between overlapping floor and wall insulation. Insulation and insulating blocks may be either above or below the floor structure, but above is recommended. This will allow the use of less dense blocks (of lower thermal conductivity), since they will not have to support the weight of the floor. Also, above the structure they will be above the dpc, where their lower moisture content will give a lower thermal conductivity than below the dpc. Heat loss from the floor can be further reduced by extending the cavity insulation down to, or below, the lower edge of the suspended floor.

B.7.4 Construction F4: Exposed floor: timber joists, insulation between joists

Diagram B21

Para. B.7.4

Exposed timber floor, insulation between joists

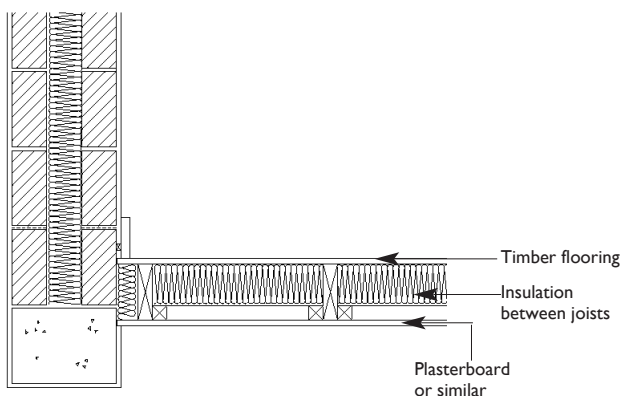

Installation guidance and precautions

The flooring on the warm side of the insulation should have a higher vapour resistance than the outer board on the cold side. If necessary, a vapour check should be laid across the warm side of the insulation. Methods of avoiding thermal bridging at junctions with internally insulated and cavity insulated walls are similar to those described for suspended timber ground floors above.

Table B22: **U-values for exposed timber floors, insulation between timber joists, plasterboard finish.**

Exposed Perimeter/Area (P/A)(m-)	Thermal conductivity of insulation (W/mK)				
	0.040	0.035	0.030	0.025	0.020
	Total Thickness of insulation (mm)				
100	0.41	0.37	0.34	0.31	0.27
120	0.35	0.32	0.29	0.26	0.23
140	0.31	0.28	0.25	0.23	0.20
160	0.27	0.25	0.23	0.20	0.18
180	0.25	0.22	0.20	0.18	0.16
200	0.22	0.20	0.19	0.17	0.15

This table is derived for floors with:
 20 mm timber flooring ($\lambda = 0.13$), insulation as specified in table between timber joists ($\lambda = 0.13$) of equal depth, 13 mm plasterboard ($\lambda = 0.25$). The calculations assume a fractional area of timber thermal bridging of 11%. (See [Diagram B21](#))

B.7.5 Construction F5: Exposed floor: solid concrete, insulation external

With cavity wall insulation, thermal bridging may be minimised by supporting the external leaf independently, and continuing the external floor insulation around the edge beam to connect with the cavity insulation as shown in [Diagram B22](#).

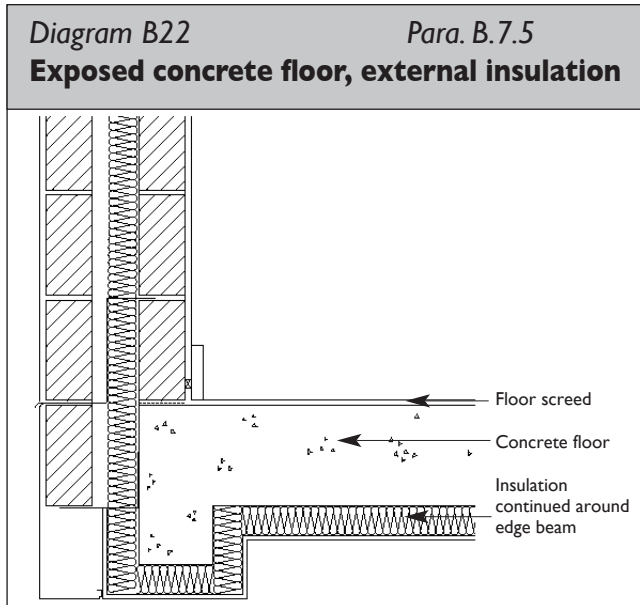

Table B23: U-values for exposed concrete floors, external insulation, external render

Exposed Perimeter/Area (P/A)(m-)	Thermal conductivity of insulation (W/mK)				
	0.040	0.035	0.030	0.025	0.020
	Total Thickness of insulation (mm)				
60	0.54	0.48	0.42	0.36	0.30
80	0.42	0.38	0.33	0.28	0.23
100	0.35	0.31	0.27	0.23	0.19
120	0.30	0.26	0.23	0.19	0.16
140	0.26	0.23	0.20	0.17	0.14
160	0.23	0.20	0.18	0.15	0.12

This table is derived for floors with: 150 mm cast concrete ($\lambda = 1.35$), insulation, 20 mm external render. (See [Diagram B22](#)).

Installation guidance and precautions

If the walls are internally insulated, this floor construction is not recommended. Floor insulation should instead be located internally in order to connect with the wall insulation.

Table B24: Indicative U-values (W/m²K) for windows, doors and roof windows

The values apply to the entire area of the window opening, including both frame and glass, and take account of the proportion of the area occupied by the frame and the heat conducted through it. If the U-value of the components of the window (glazed unit and frame) are known, window U-values may alternatively be taken from the tables in Annex F of I.S. EN ISO 10077-1, using the tables for 20% frame for metal-framed windows and those for 30% frame for wood or PVC-U framed windows.

When available, the manufacturer's certified U-values for windows or doors should be used in preference to the data in this table. Adjustments for roof indows should be applied to manufacturer's window U-values unless the manufacturer provides a U-value specifically for a roof window.

Table B24 Indicative U-values (W/m ² K) for windows, doors and rooflights						
	Type of frame					
	Window with wood or PVC-U frame (use adjustment in Note 1)			Window with metal frame with 4mm thermal break (use adjustments in Note 2)		
	6 mm gap	12 mm gap	16 or more mm gap	6 mm gap	12 mm gap	16 or more mm gap
double-glazed, air filled	3.1	2.8	2.7	3.7	3.4	3.3
double-glazed, air filled (low-E, $\hat{\Delta}n = 0.2$, hard coat)	2.7	2.3	2.1	3.3	2.8	2.6
double-glazed, air filled (low-E, $\hat{\Delta}n = 0.15$, hard coat)	2.7	2.2	2.0	3.3	2.7	2.5
double-glazed, air filled (low-E, $\hat{\Delta}n = 0.1$, soft coat)	2.6	2.1	1.9	3.2	2.6	2.4
double-glazed, air filled (low-E, $\hat{\Delta}n = 0.05$, soft coat)	2.6	2.0	1.8	3.2	2.5	2.3
double-glazed, argon filled	2.9	2.7	2.6	3.5	3.3	3.2
double-glazed, argon filled (low-E, $\hat{\Delta}n = 0.2$, hard coat)	2.5	2.1	2.0	3.0	2.6	2.5
double-glazed, argon filled (low-E, $\hat{\Delta}n = 0.15$, hard coat)	2.4	2.0	1.9	3.0	2.5	2.4
double-glazed, argon filled (low-E, $\hat{\Delta}n = 0.1$, soft coat)	2.3	1.9	1.8	2.9	2.4	2.3
double-glazed, argon filled (low-E, $\hat{\Delta}n = 0.05$, soft coat)	2.3	1.8	1.7	2.8	2.2	2.1
triple glazed, air filled	2.4	2.1	2.0	2.9	2.6	2.5
triple-glazed, air filled (low-E, $\hat{\Delta}n = 0.2$, hard coat)	2.1	1.7	1.6	2.6	2.1	2.0
triple-glazed, air filled (low-E, $\hat{\Delta}n = 0.15$, hard coat)	2.1	1.7	1.6	2.5	2.1	2.0
triple-glazed, air filled (low-E, $\hat{\Delta}n = 0.1$, soft coat)	2.0	1.6	1.5	2.5	2.0	1.9
triple-glazed, air filled (low-E, $\hat{\Delta}n = 0.05$, soft coat)	1.9	1.5	1.4	2.4	1.9	1.8
triple-glazed, argon filled	2.2	2.0	1.9	2.8	2.5	2.4
triple-glazed, argon filled (low-E, $\hat{\Delta}n = 0.2$, hard coat)	1.9	1.6	1.5	2.3	2.0	1.9
triple-glazed, argon filled (low-E, $\hat{\Delta}n = 0.15$, hard coat)	1.8	1.5	1.4	2.3	1.9	1.8
triple-glazed, argon filled (low-E, $\hat{\Delta}n = 0.1$, soft coat)	1.8	1.5	1.4	2.2	1.9	1.8
triple-glazed, argon filled (low-E, $\hat{\Delta}n = 0.05$, soft coat)	1.7	1.4	1.3	2.2	1.8	1.7
Windows and doors, single glazed		4.8			5.7	
Solid wooden door		3.0				

Notes:

(1) For roof windows with wooden or PVC-U frames apply the following adjustments to U-values:

Wood or PVC-U frame	U-value adjustment for roof window, W/m²K
----------------------------	---

Single glazed	+0.3
Double glazed	+0.2
Triple glazed	+0.2

(2) For windows or roof windows with metal frames apply the following adjustments to U-values:

Metal frames	Adjustment to U-value, W/m²K	
	Window	Roof window

Metal, no thermal break	+0.3	+0.7
Metal, thermal break 4 mm	0	+0.3
Metal, thermal break 8 mm	-0.1	+0.2
Metal, thermal break 12 mm	-0.2	+0.1
Metal, thermal break 20 mm	-0.3	0
Metal, thermal break 32 mm	-0.4	-0.1

(3) For doors which are half-glazed (approximately) the U-value of the door is the average of the appropriate window U-value and that of the non-glazed part of the door (e.g. solid wooden door [Uvalue of 3.0 W/m²K] half-glazed with double glazing [low-E, hard coat, argon filled, 6 mm gap, Uvalue of 2.5 W/m²K] has a resultant U-value of $0.5(3.0+2.5) = 2.75$ W/m²K).

Source: DEAP Manual Version 2.1 January 2007

Appendix C: Reference values for calculation of Maximum Permitted Energy Performance Coefficient (MPEPC) and Maximum Permitted Carbon Performance Coefficient (MPCPC)

C.1 This Appendix provides a set of reference values for the parameters of an NEAP calculation, which are used to establish a Maximum Permitted Energy Performance Coefficient (MPEPC) and Maximum Permitted Carbon Performance Coefficient (MPCPC) for the purposes of demonstrating compliance with Regulation L4(a) for buildings other than dwellings.

C.2. Table C1 defines a notional Reference Building used to establish the MPEPC and MPCPC for the actual building being assessed for compliance in accordance with Section 1.1 of this document.

Table C1: Reference values for calculation of Maximum Permitted Primary Energy Performance Coefficient (MPPEPC) and Maximum Permitted Carbon Performance Coefficient (MPCPC) for buildings (other than a dwelling).

Element or system	Reference Values/ Specifications
Total floor area and building volume	Same as actual building
Opening areas (windows and doors) All external walls shall be taken to have windows and doors and all roofs shall be taken to have roof lights.	Residential buildings where people temporarily or permanently reside. Windows and pedestrian doors are 30% of the total area of exposed walls Roof lights are 20% of roof area
The reference building shall be taken to have the same areas of pedestrian doors, vehicle access doors and display window as the actual building. If the total area of these elements is less than the allowances listed in the right hand column the balance shall be made up of windows and roof lights. If the total area exceeds the allowances no windows or roof lights will be added.	Places of assembly, offices and shops Windows and pedestrian doors are 40% of the total area of as the exposed walls Roof lights are 20% of roof area Industrial and storage buildings Windows and pedestrian doors are 15% of the total area of exposed walls. Roof lights are 20% of roof area
Vehicle access doors	Same area as actual building
Pedestrian doors	Same area as actual building
Display windows	Same area as actual building
High usage entrance doors	Not included in reference building
Walls	$U = 0.27 \text{ W/m}^2\text{K}$
Roof	$U = 0.16 \text{ W/m}^2\text{K}$
Windows, roof lights and glazed doors	$U = 2.2 \text{ W/m}^2\text{K}$ Solar energy transmittance = 0.72 Light transmittance = 0.76
Display windows	$U = 6.0 \text{ W/m}^2\text{K}$ Solar energy transmittance = 0.72 Light transmittance = 0.00
External personnel doors	$U = 2.2 \text{ W/m}^2\text{K}$
Vehicle access and similar large doors	$U = 1.5 \text{ W/m}^2\text{K}$
Ground and other exposed floors	$U = 0.25 \text{ W/m}^2\text{K}$ Area: same as actual building

Table C1: Reference values for calculation of Maximum Permitted Primary Energy Performance Coefficient (MPPEPC) and Maximum Permitted Carbon Performance Coefficient (MPCPC) for buildings (other than a dwelling).

Element or system	Reference Values/ Specifications
Effective Thermal Capacity	External wall = 11.7 kJ/m ² K Roof = 12.0 kJ/m ² K Ground floor = 36.0 kJ/m ² K Internal wall = 11.9 kJ/m ² K Internal floor = 8.6 kJ/m ² K Internal ceiling = 8.6 kJ/m ² K
Allowance for thermal bridging	Add 16% to calculated heat loss through building elements
Shading and orientation	Same as actual building
Air permeability	Infiltration due to structure = 10m ³ /h/m ² at 50 Pa
Fuel	Auxiliary energy = grid electricity Cooling = grid electricity Domestic hot water (DHW) = as actual building ¹ Space heating = as actual building ¹ Note 1: use of renewable energy is not assumed for the reference building; Where a combination of renewable and non-renewable energies used in actual building, full provision is assumed to be by the non-renewable source in the reference building; where full provision is by renewable source in actual building, natural gas is assumed in reference building.
Cooling Seasonal Energy Efficiency Ratio (SEER)	Air conditioned building SEER = 1.67
Heating System Coefficient of Performance (SCoP)	Heating only SCoP = 0.73 Mechanical ventilation (no cooling) SCoP = 0.78 Air conditioned SCoP = 0.83
Auxiliary Energy	No mechanical services = 0 kWh/m ² Heating only = 1.8 kWh/m ² Mechanical ventilation (no cooling) = Multiply the specific fan power by the minimum ventilation requirement and occupation period appropriate to the activity in the space Air conditioned = maximum of: (a) Fresh air rate multiplied by the annual hours of operation for full occupancy by a specific fan power of 2.0 W/(litre/s). If the activity in the space requires the use of HEPA filters, a specific fan power of 3.0 W/(litre/s) is used (b) 8.5 W/m ² multiplied by the annual hours of operation

Table C1: Reference values for calculation of Maximum Permitted Primary Energy Performance Coefficient (MPPEPC) and Maximum Permitted Carbon Performance Coefficient (MPCPC) for buildings (other than a dwelling).
Contd...

Element or system	Reference Values/ Specifications
Lighting – installed power density	<p>Office, storage and industrial spaces = divide the illuminance appropriate to the activity area by 100, then multiply by 3.75 W/m² per 100 lux</p> <p>For other spaces = divide the illuminance appropriate to the activity area by 100, then multiply by 5.2 W/m² per 100 lux</p>
Lighting controls	Local manual switching only in all spaces.
<p>Activity</p> <p>The following parameters are fixed for each activity and building type:</p> <ul style="list-style-type: none"> a) Heating and cooling temperature and humidity set points b) Lighting standards c) Ventilation standards d) Occupation densities and associated internal gains e) Gains from equipment f) Internal moisture gains for kitchens and swimming pools g) Duration when these set points, standards, occupation standards, occupation densities and gains to be maintained h) Set back conditions when the conditions listed in (g) are not maintained i) Hot water demand 	Same as actual building

Appendix D: Thermal Bridging

GENERAL

D.1 This Appendix deals with the assessment of discreet thermal bridging, e.g. at junctions and around openings such as doors and windows. It gives guidance on

- avoidance of mould growth and surface condensation, and
- limiting factors governing additional heat losses.

The guidance is based on IP 1/06 “Assessing the effects of thermal bridging at junctions and around openings” published by BRE and can be used to demonstrate adequate provision to limit thermal bridging when the guidance in relation to appropriate detailing of cills, jambs, lintels, junctions between elements and other potential thermal bridges contained in Paragraphs 1.2.4.2 and 1.2.4.3, and associated reference documents, is not followed.

MOULD GROWTH AND SURFACE CONDENSATION

D.2 Details should be assessed in accordance with the methods described in I.S. EN ISO 10211-1: and I.S. EN ISO 10211-2. This assessment should establish the temperature factor (f_{Rsi}) and linear thermal transmittance (ψ).

The temperature factor (f_{Rsi}) is defined as follows:

$$f_{Rsi} = (T_{si} - T_e) / (T_i - T_e)$$

where:

T_{si} = minimum internal surface temperature,

T_e = external temperature, and

T_i = internal temperature.

The linear thermal transmittance (ψ) describes the heat loss associated with a thermal bridge. This is a property of a thermal bridge and is the rate of heat flow per degree per unit length of bridge that is not accounted for in the U-values of the plane building elements containing the thermal bridge.

D.3 The value of f_{Rsi} should be greater than or equal to 0.75, so as to avoid the risk of mould growth and surface condensation. For three-dimensional corners of ground floors this value may be reduced to 0.70, for all points within 10 mm of the point of lowest f_{Rsi} .

CALCULATION PROCEDURES

D.4 Details can be assessed and the calculated value used in the calculation of overall heat loss due to thermal bridging.

Details should be assessed in accordance with the methods described in IS EN ISO 10211 Parts 1 and 2. These calculations of two dimensional or three dimensional heat flow require the use of numerical modeling software. To be acceptable, numerical modeling software should model the validation examples in IS EN ISO 10211 with results that agree with the stated values of temperature and heat flow within the tolerance indicated in the standard for these examples. Several packages are available that meet this requirement.

Detailed guidance on decisions regarding specific input to the modeling software and the determination of certain quantities from the output of the software is contained in BRE Report BR 497 Conventions for calculating linear thermal transmittance and temperature factors. This guidance should be followed in carrying out modeling work so that different users of the same software package and users of different software packages can obtain correct and consistent results.

<i>Table D1:</i> Maximum values of linear thermal transmittance (ψ) for selected locations	
Detail in external element/junction with external element	Maximum value of ψ (W/mK)
Windows/doors	
Steel lintel with perforated steel baseplate	0.50
Other lintel (including other steel lintel)	0.30
Cills/jambs	0.06
Junctions with external element	
Ground floor, intermediate floor, Party wall	0.16
Eaves (ceiling level)	0.06
Gable (ceiling level)	0.24
Note: For party walls and intermediate floors between buildings, half of the ψ -value should be applied to each building when assessing the additional heat loss associated with bridging.	

Table D2: Linear Thermal Transmittance Values for Acceptable Construction Details for use in NEAP

Type of Junction	ψ (W/mK)
Roof-Wall	0.12
Wall-Ground floor	0.16
Wall-Wall (corner)	0.09
Wall-Floor (not ground floor)	0.07
Lintel above window or door	0.3
Sill below window	0.04
Jamb at window or door	0.05

Appendix E: Avoidance of Solar Overheating

E1 This Appendix provides the detail for the procedure referred to in paragraph 1.2.6.2 (a).

E2 When estimating the solar load, the space being considered should be split into perimeter and interior zones. “Perimeter zones” are those defined by a boundary drawn a maximum of 6 m away from the window wall(s). Interior zones are defined by the space between this perimeter boundary and the non-window walls or the perimeter boundary of another perimeter zone.

When calculating the average solar cooling load, the contribution from all windows within that zone should be included, plus the contribution from any rooflight (or part rooflight) that is within the zone boundary.

For interior zones, the contribution from all rooflights (or part rooflights) that is within its zone boundary should be included.

For each zone within the space, the total average solar cooling load per unit floor area should be no greater than 25 W/m².

The total average solar cooling load per unit floor area (W/m²) is calculated as follows:

- The **average solar cooling load** associated with each glazed area is calculated by multiplying the area of glazing by the solar load for the appropriate orientation (see [Table Z](#)) and by a correction factor applicable to the relevant glazing/blind combination (see Paragraph E3 and [Table E1](#));
- The average solar cooling loads thus calculated are added together and the sum divided by the zone floor area to give a total average solar cooling load per unit floor area (W/m²).

Where the actual glazed area is not known, it can be assumed to equate to the opening area reduced by an allowance for framing. The default reduction should be taken as 10% for windows and 30% for rooflights.

E3 Standard correction factors for intermittent shading using various glass/blind combinations are given in [Table E1](#).

Table E1: Correction factors for intermittent shading using various glass/blind combinations

Glazing/blind combination (described from inside to outside)	Correction factor (f _c)
Blind/clear/clear	0.95
Blind/clear/reflecting	0.62
Blind/clear/absorbing	0.66
Blind/low-e/clear	0.92
Blind/low-e/reflecting	0.60
Blind/low-e/absorbing	0.62
Clear/blind/clear	0.69
Clear/blind/reflecting	0.47
Clear/blind/absorbing	0.50
Clear/clear/blind/clear	0.56
Clear/clear/blind/reflecting	0.37
Clear/clear/blind/absorbing	0.39
Clear/clear/blind	0.57
Clear/clear/clear/blind	0.47

Where available shading coefficient data for a particular device should be used to calculate the correction factor, in preference to using the figures given in [Table E1](#). The correction factor is calculated as follows:

- (a) For fixed shading (including units with absorbing or reflecting glass), the correction factor (f_c) is given by

$$f_c = S_c/0.7$$

- (b) For moveable shading, the correction factor is given by

$$f_c = 0.5(1 + (S_c/0.7))$$

where S_c is the shading coefficient for the glazing/shading device combination, i.e. the ratio of the instantaneous heat gain at normal incidence by the glazing/shading combination relative to the instantaneous heat gain by a sheet of 4 mm clear glass.

- (c) Where there is a combination of fixed and moveable shading, the correction factor is given by

$$f_c = (S_{cf} + S_{ctot})/1.4$$

where S_{cf} is the shading coefficient of the fixed shading (with glazing) and S_{ctot} is the shading coefficient of the combination of glazing and fixed and moveable shading.

Example E1

E4 A school classroom is 9 m long by 6 m deep, with a floor to ceiling height of 2.9 m. There is glazing on one wall, with rooflights along the internal wall opposite the window wall. The windows are 1200 mm wide by 1000 mm high, and there are six such windows in the external wall, which faces SE. The windows are clear double glazed, with mid-pane blinds, of wooden frames with a framing percentage of 25%. There are three 0.9 m² horizontal rooflights, with an internal blind and low-e glass on the inner pane of the double pane unit. Is there likely to be a solar overheating problem?

- (a) As the room is not more than 6 m deep, it should be considered as a single “perimeter zone” – there is no “interior zone”
- (b) The calculation of the average solar cooling load (W) is set out in the following Table

Element/ Orientation	Windows (SE)	Rooflight
Opening Area (m ²)	7.2	2.7
Frame correction	0.75	0.7
Glazing/blind correction (Table E1)	0.69	0.92
Average solar load per unit glazed area (W/m ²) (Table 7)	198	327
Average solar load (W)	738	569
Total Average Load (W)	1307	

- (c) the total average solar cooling load per unit floor area (W/m²) is derived by dividing the total average solar load by the zone floor area. In this case the floor area is 54 m² and the total average solar cooling load per unit floor area is 24.20 (W/m²). As this is less than 25 W/m², there is not likely to be an overheating problem.

Example E2

E5 An office building has a floor to ceiling height of 2.8 m and curtain walling construction with a glazing ratio of 0.6. The long side of the office faces south and the short side faces west. On each floor, the main office area is open plan, but there is a 5 m by 3 m corner office, with the 5 m side facing South. It is proposed to use double glazing with the internal pane low-e glazing and the external pane absorbing glass, and with an internal blind.

For the open plan areas, the perimeter zone is defined by the 6 m depth rule, but for the corner office, it is defined by the partitions. The glazed area is taken as the nominal area less 10% for framing. Three different situations must be considered

- the south facing open plan area;
- the west facing open plan area; and
- the corner office.

Open plan area

From Table 7, it can be seen that the solar loading for a West orientation (205 W/m²) exceeds that for a South orientation (156 W/m²). Thus, on the assumption that the same construction would be used on West and South facades, it is sufficient to check the West orientation for the open plan offices.

For a typical 5 m length of West facing office, the floor area of the perimeter zone is 30 m², and the area of glazing is 7.56 m², i.e. width (5 m) x height (2.8 m) x glazing ratio (0.6) x framing correction (0.9). The glazing/blind correction factor is 0.62 and the solar loading is 205 W/m². Thus the total average solar cooling load per unit floor area (W/m²) is

$$(7.56 \times .62 \times 205)/30 = 32\text{W/m}^2.$$

As this is greater than the threshold of 25 W/m², it is necessary to decrease the glazing ratio or provide alternative or additional shading devices, e.g. a reduction in glazing ratio to 0.47 or provision of fixed shading devices which would provide a shading coefficient of 0.34 (giving a correction factor of 0.43), or a combination of these measures would reduce the risk of solar overheating to acceptable levels.

If the corner office was not partitioned from a general open floor area, it's solar load could be considered as part of the load of one of the facades it shares.

Corner Office

For the purpose of this example, it is assumed that it has been decided to reduce the glazing ratio of the building to 0.47. On this basis the average solar load for this office can be calculated as set out in the following table.

Element/ Orientation	South Facade	West Facade
Nominal Glazed Area (m ²)	6.8	3.95
Frame correction	0.9	0.9
Glazing/blind correction (Table E1)	0.62	0.62
Average solar load per unit glazed area (W/m ²) (Table 7)	156	205
Average solar load (W)	573	452
Total Average Solar Load (W)	1025	

The office floor area is 15 m² and the total average solar cooling load per unit floor area (W/m²) is 68 W/m².

To achieve a total average solar cooling load per unit floor area (W/m²) of 25 W/m² would require a reduction in the total average solar load to 375 W. This can be achieved by a further reduction of glazing area, e.g. through the use of opaque panels so as to reduce the glazing ratio for the corner office to 17%. An alternative would be to use external shading devices to give a correction factor of 0.22. This implies fixed shading with a shading coefficient of 0.16. Such a shading coefficient is quite demanding to achieve in practice. Alternatively a more detailed calculation could be undertaken.

Standards and Other References

Standards referred to:

I.S. 161: 1975 Copper direct cylinders for domestic purposes.

I.S. 325-1: 1986 Code of Practice for use of masonry - part 1: Structural use of unreinforced masonry.

I.S. EN 1745: 2002 Masonry And Masonry Products - Methods for determining Design Thermal Values.

I.S. EN ISO 6946: 1997 Building components and building elements –Thermal resistance and thermal transmittance – Calculation method Amd 1 2003.

I.S. EN ISO 8990: 1997 Thermal insulation – Determination of steady-state thermal transmission properties – Calibrated and guarded hot box.

I.S. EN ISO 10077-1: 2001 Thermal performance of windows, doors and shutters – Calculation of thermal transmittance – Part 1: simplified method.

I.S. EN 10077-2: 2000 Thermal performance of windows, doors and shutters – Calculation of thermal transmittance – Part 2: Numerical methods for frames.

I.S. EN ISO 10211-1: 1996 Thermal bridges in building construction – heat flows and surface temperatures. Part 1 general calculation methods.

I.S. EN ISO 10211-2: 2001 Thermal bridges in building construction – heat flows and surface temperatures. Part 2 linear thermal bridges.

I.S. EN ISO 10456: 2000 Building materials and products - procedures for determining declared and design thermal values.

I.S. EN 12524: 2000 Building materials and products – Hygrothermal properties – Tabulated design values.

I.S. EN ISO 12567-1: 2001 Thermal performance of windows and doors – Determination of thermal transmittance by hot box method – Part 1: Complete windows and doors.

I.S. EN ISO 13370: 1999 Thermal performance of buildings – Heat transfer via the ground – Calculation methods.

I.S. EN ISO 13789: 2000 Thermal Performance of Buildings – Transmission Heat Loss Coefficient – Calculation Method.

I.S. EN 13829: 2000 Thermal Performance of Buildings: Determination of air permeability of buildings: fan pressurisation method.

BS 747: 2000 Reinforced bitumen sheets for roofing – Specification.

BS 1566 Part 1: 2002 Copper indirect cylinders for domestic purposes, open vented copper cylinders. Requirements and test methods.

BS 5422 : 2001 Method for specifying thermal insulating materials for pipes, tanks, vessels, ductwork

and equipment (operating within the temperature range - 400C to + 7000C).

BS 8206 Part 2: 1992 Lighting for buildings. Code of practice for daylighting.

Other Publications referred to:

BRE Digest 465, U-values for light steel frame construction, BRE, 2002.

BRE Information Paper I/06 Assessing the effects of thermal bridging at junctions and around openings, BRE, 2001.

BRE Information Paper 10/02, Metal cladding: assessing the thermal performance of built-up systems using 'Z' spacers, BRE, 2002

BRE Information Paper I/06 Assessing the affects of thermal bridging at junctions and around openings, BRE 2006

BRE Report BR 262, Thermal Insulation: avoiding risks, BRE, 2001

BRE Report BR 364, Solar shading of buildings, BRE, 1999

BRE Report BR 443, Conventions for U-value Calculations, BRE, 2002.

BRE Report BR 497, Conventions for calculating linear thermal transmittance and temperature factors, BRE, 2007

CIBSE Guide A: Environmental Design - Section 3: Thermal Properties of Buildings and Components, CIBSE, 1999

CIBSE TM 23: Testing Buildings for Air Leakage, CIBSE, 2000

Chris Knights and Nigel Potter, Airtightness Testing for New Dwellings, A BSRIA Guide ,BSRIA, 2006

DEHLG, Limiting Thermal Bridging and Air Infiltration - Acceptable Construction Details available on www.environ.ie

Domestic Energy Assessment Procedure (DEAP) SEI 2006 (www.sei.ie)

Good Practice Guide 268, Energy efficient ventilation in dwellings – a guide for specifiers, 2006

Home-heating Appliance Register of Performance (HARP) database, SEI (www.sei.ie/harp).

Heating and Domestic Hot Water Systems for dwellings – Achieving compliance with Part L.

MCRMA Technical Paper No. 14, Guidance for the design of metal roofing and cladding to comply with Approved Document L2:2001, The Metal Cladding and Roofing Manufacturers Association, 2002

SCI Technical Information Sheet 312, Metal cladding: U-value calculation - assessing thermal performance of built-up metal roof and wall cladding systems using

rail and bracket spacers, The Steel Construction Institute, 2002

SI. No. 260 of 1994, European Communities (Efficiency requirements for hot water boilers fired with liquid or gaseous fuels) Regulations, 1994, The Department of Transport, Energy and Communications, 1994

Other Useful Standards and Publications

IS EN 14785: 2006 Residential space heating appliances fired by wood pellets - requirements and test methods

I.S. EN 303-5: 1999 Heating boilers - heating boilers for solid fuels, hand and automatically stoked, nominal heat output of up to 300 kw - terminology requirements, testing and marking

Pr EN 15270: Pellet burners for small heating boilers - Definitions, requirements, testing, marking (Expected to be adopted as IS EN 15270 in 2008)

IS EN 12975-1: 2006 Thermal solar systems and components - solar collectors - part 1: general requirements

IS EN 12975-2: 2006 Thermal solar systems and components - solar collectors - part 2: test methods

IS EN 12976-1: 2006 Thermal solar systems and components - factory made systems - part 1: general requirements

IS EN 12976-2 : 2006 Thermal solar systems and components - factory made systems - part 2: test methods

IS ENV 12977-1: 2001 Thermal solar systems and components - custom built systems - part 1: general requirements

IS ENV 12977-2 : 2001 Thermal solar systems and components - custom built systems - part 2: test methods

ISO 9806-1: 1994 Test methods for solar collectors - part 1: thermal performance of glazed liquid heating collectors including pressure drop

ISO 9806-2: 1995 Test methods for solar collectors - part 2: qualification test procedures

ISO 9806-3: 1995 Test methods for solar collectors - part 3: thermal performance of unglazed liquid heating collectors (sensible heat transfer only) including pressure drop

IS EN 14511-1: 2004 Air conditioners, liquid chilling packages and heat pumps with electrically driven compressors for space heating and cooling - part 1: terms and definitions

IS EN 14511-2 :2004 Air conditioners, liquid chilling packages and heat pumps with electrically driven compressors for space heating and cooling - part 2: test conditions

IS EN 14511-3: 2004 Air conditioners, liquid chilling packages and heat pumps with electrically driven compressors for space heating and cooling - part 3: test methods

IS EN 14511-4: 2004 Air conditioners, liquid chilling packages and heat pumps with electrically driven compressors for space heating and cooling - part 4: requirements

I.S. EN 12664: 2001 Thermal performance of building materials and products – Determination of thermal resistance by means of guarded hot plate and heat flow meters method – Dry and moist products of low and medium thermal resistance.

I.S. EN 12667: 2001 Thermal performance of building materials and products – Determination of thermal resistance by means of guarded hot plate and heat flow meters method – Products of high and medium thermal resistance.

I.S. EN 12828: 2003 Heating systems in buildings - design for water-based heating systems.

I.S. EN 12939: 2001 Thermal performance of building materials and products – Determination of thermal resistance by means of guarded hot plate and heat flow meters method – Thick products of high and medium thermal resistance.